

DAVIDE PEDERSOLI

Since 1957



Made in Italy



I nostri primi cinquant'anni

L'attività della nostra azienda, iniziata cinquant'anni fa da mio papà Davide (1924-1996) con la fabbricazione di fucili da caccia, si delineò dopo pochissimi anni nel settore delle armi ad avancarica, dei loro accessori e di armi a retrocarica, in particolare modelli specifici della storia americana che va dal 1700 al 1890.

La missione della nostra azienda è stata ed è quella di riproporre la storia offrendo dei prodotti di qualità superiore. Oggi, grazie alla nostra completa autonomia produttiva avviata già da molti anni, tutti i componenti necessari per l'assemblaggio delle armi vengono fabbricati all'interno dell'azienda, con il vantaggio di potere seguire ogni fase di progettazione e di lavorazione e con il prestigioso risultato di aver reso i modelli firmati **Davide Pedersoli** famosi in tutto il mondo per la qualità, per la funzionalità e per la precisione balistica.

I tiratori, i cacciatori, i collezionisti e gli appassionati della rievocazione storica, gli abituali destinatari del prodotto Pedersoli, avranno sempre la certezza di possedere un'arma realizzata con estrema cura e con materiali di elevata tecnologia.

Una testimonianza della validità delle nostre armi risiede senz'altro nella lunghissima serie di primati nelle competizioni sportive, suffragata da una grande quantità di medaglie conquistate nei vari campionati internazionali.

Ogni traguardo raggiunto in campo agonistico costituisce il premio più bello per la continua crescita che l'azienda ha maturato negli anni. Ma questo è solo uno degli aspetti di cui possiamo essere orgogliosi: vogliamo anche sottolineare il saldo legame con il mondo della rievocazione storica in cui i vari studiosi, sempre molto attenti ai dettagli di ogni modello, ci aiutano con le indicazioni riguardanti eventuali piccole modifiche da apportare per una migliore risposta alle richieste dei collezionisti.

Nell'immediato futuro l'azienda manterrà l'impostazione a carattere familiare: uno dei progetti attuali più importanti è la formazione dei nostri figli che, inseriti già in azienda, costituiranno la terza generazione di Casa Pedersoli. E sono proprio i giovani a volere continuare la strada intrapresa da nonno Davide, lavorando in sintonia con ogni utente e ascoltando ogni prezioso suggerimento, consapevoli della continua espansione dell'universo delle armi storiche.

In occasione del cinquantenario, unendomi agli staff tecnici e direttivi, intendo ringraziare tutti coloro che hanno riposto nell'azienda e nei suoi prodotti la loro fiducia e la loro stima, e che l'hanno aiutata a festeggiare questo importante e prestigioso traguardo.

Pierangelo Pedersoli



Our first fifty years

The activity of our company started fifty years ago by my father Davide (1924-1996) manufacturing hunting shotguns and, after a few years, the direction changed towards muzzle loading guns, their accessories and cartridge rifles, particularly for models specific from the 1700's to the 1890's of the American firearm history.

The mission of our company has been to recreate that history by offering products having authenticity and superior quality. Today, thanks to our complete production autonomy started many years ago, all the components needed to assemble a gun are manufactured inside the company, with the advantage to control every working phase from the project design to the manufacturing, with the prestigious result that made Davide Pedersoli's products famous in the world for the quality, the working reliability and the ballistic precision.

The shooters, the hunters, the collectors and those fond of the historical re-enactment, who are the customers of Pedersoli's products, will always have the certainty to own a gun made with care and with high technology materials. One witness of our guns validity is, without doubt, in the very long series of records seen in the shooting competitions and countless medals won in the various international matches. Every medal won at the range serves as another example of the continuous

growth and maturing that the company has made during the years. But this is only one of the aspects of which we can be proud: we also want to underline the firm relation we have with the world of the historical re-enactment in which several historical researchers, always paying attention to the details of each model, help us by indicating small modifications which best answer the collectors' requests.

In the immediate future, the company will keep the family management: one of the most important current projects is the formation of our sons, who, working in the company, will be the third generation in the Pedersoli's company.

The young generation wants to continue the road taken by the grand father Davide, working on behalf of and in cooperation with each customer, listening to every suggestion and aware of the continuous universe expansion of the historical guns.

On this occasion of our fiftieth Anniversary, together with the technical and management staff, I wish to thank all who gave their trust to the company and its products and for their confidence and esteem in helping us to enjoy this important milestone event in our company's history.

Pierangelo Pedersoli



La Davide Pedersoli si riserva il diritto di apportare in ogni momento, a suo discrezione e senza preavviso, migliorie o modifiche ai propri prodotti. Le descrizioni, le illustrazioni ed i dati tecnici contenuti in cataloghi, opuscoli non hanno carattere impegnativo.

Davide Pedersoli & Co. reserve to themselves, at any time and without previous notifications, the right to effect changes to their products. Descriptions, pictures or technical information carried on catalogues or leaflets do not imply any kind of engagement.



L.341

L.341

S.340

S.341

WORLD CHAMPION

Leusden (NL) 1990
Bordeaux (F) 2006 (Team)



S.341 L.341 S.340

MANG IN GRAZ

Mod. S.341 Standard
Mod. L.341 Deluxe
Mang in Graz Match
Mod. S.340

Esatta riproduzione di una pistola austriaca da tiro prodotta da Martin Mang in Graz. In quest'arma, Mang ha espresso le più raffinate tecniche europee della fine dell'era a percussione. Il calcio, in noce europeo finito a olio, presenta un'ideale impugnatura a scanalature di stile Impero. La canna ottagonale conica è color damasco. È dotata di stecher regolabile con molle

(1850 c.)
a lamina e congegni di mira regolabili e le parti metalliche presentano una finitura color argento vecchio nella versione standard e color tartaruga nel modello Match.
Nella versione Deluxe, anche l'incisione è un'esatta riproduzione del modello originale. Il calcio è in noce, lucidato a tampone così da esaltarne le venature. Tutte le parti sono interamente incise con motivi floreali, di pregevole fattura. Sul tappo canna è incisa una maschera tipica del periodo; sulla canna e sulla codetta sono state eseguite delle incisioni con rimessi in oro.

MANG IN GRAZ

Mod. S.341 Standard
Mod. L.341 Deluxe
Mang in Graz Match
Mod. S.340

(1850 c.)
This pistol reproduces to the tiniest details the original model produced by Martin Mang in Graz. In this pistol, Mang has demonstrated the ultimate European technique in use during the last years of the percussion era. The stock, from select walnut, is oil finished and enriched with a typical, imperial style, fluted grip. The octagonal, rifled barrel is rust

brown finish colour and provided with adjustable single set trigger. The metal parts have a coin colour finishing for the standard version and case hardened colour for the Match model. In the Deluxe version the engraving faithfully reproduces the original model. The fancy striped walnut stock is enhanced by the oiled hand finish. All metal parts are engraved with floral motives. The breech plug shows a typical mask of the period. Barrel and tang are enriched with gold inlays.

Mod.	Cal.	Righe Grooves	Passo Twist mm - inches	Lungh. canna Barrel length mm - inches	Lungh. totale Overall length mm - inches	Peso Weight kg - lbs	Misura palla Ball/bullet size	Blocco pallottiere Bullet mould Our code
S.340 · S./L.341	.38	7	380 - 1:15	290 - 11 ⁷ / ₁₆	420 - 16 ⁷ / ₁₆	1,200 - 2.65	.375 round	USA 307-375
S.340 · S./L.341	.44	7	450 - 1:18	290 - 11 ⁷ / ₁₆	420 - 16 ⁷ / ₁₆	1,150 - 2.54	.435 round	USA 307-435

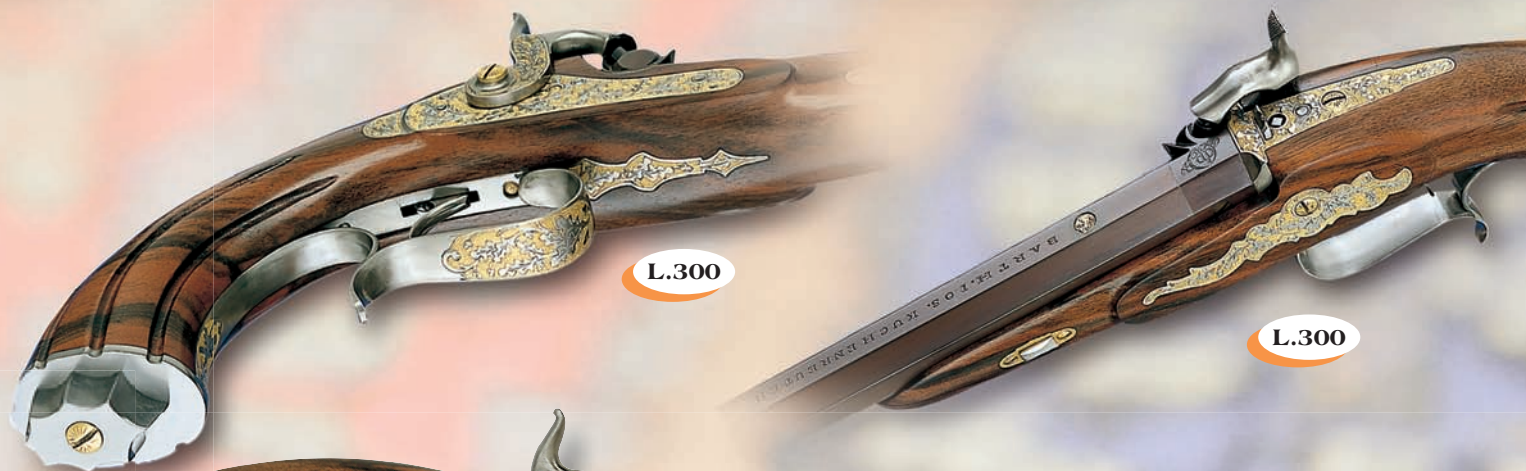

L.300

L.300



L.300



WORLD CHAMPION

Warwick (GB) 1998

S.300

S.300 L.300



KUCHENREUTER

Mod. S.300 Standard
Mod. L.300 Deluxe

Bartolomaeus Joseph Kuchenreuter visse fra il 1782 e il 1864 a Steinweg, nei pressi di Regensburg, in Germania.

Figlio di Joseph II, fu considerato fra i migliori armaioli di alto livello, oltre che tiratore di notevole successo.

Ciò spiega le elevate caratteristiche di questa pistola, quali la forma e la misura del calcio. Questo splendido modello di pistola da tiro, il cui originale fu prodotto fra il 1854 e il 1855, costituisce sicura-

mente il *master piece* della nostra produzione. Dotata di stecher a lamina e di tacca di mira regolabile in verticale, è l'arma ideale per tiratori di grande classe.

La canna, scodolabile, è color damasco e presenta incisi la scritta BARTH. Ios KUCHENREUTER e, in argento, il marchio di Kuchenreuter. Il calcio, in noce venata, è lucidato a tampone e le parti metalliche sono finite color tartaruga.

La versione Deluxe è impreziosita con una doratura sul basso fondo dell'incisione, che ne esalta la bellezza e la rarità.

(1854)

KUCHENREUTER

Mod. S.300 Standard
Mod. L.300 Deluxe

Bartholomaeus Joseph Kuchenreuter lived between 1782 - 1864 in Steinweg, near Regensburg, in Germany. He was the son of Joseph II very well known as a highly acknowledged and skilled gunmaker and, in addition, as a very good successful black powder shooter. This explains the excellent shooting characteristics of this pistol, such as the size and shape of the grip. This splendid reproduction target pistol, whose original model was produced

(1854)

around 1854/1855, is certainly the "Masterpiece" of our production. Provided with single set trigger and vertically adjustable rear sight, it is the ideal pistol for the marksman.

The barrel is rust brown finish colour with the writing: BARTH. Ios KUCHENREUTER, and the silver inlay Kuchenreuter mark. The grained walnut stock is oil finished and all metal parts are colour case hardened.

The Deluxe version is enriched with gold plating on the background of the engraving, exalting its beauty and rarity.

Mod.	Cal.	Righe Grooves	Passo Twist		Lungh. canna Barrel length		Lungh. totale Overall length		Peso Weight		Misura palla Ball/bullet size	Blocco pallottiere Bullet mould Our code
			mm	- inches	mm	- inches	mm	- inches	kg	- lbs		
S./L.300	.38	7	380	- 1:15	285	- 11 1/4	425	- 16 1/4	1,200	- 2,64	.375 round	USA 307-375
S./L.300	.44	7	450	- 1:18	285	- 11 1/4	425	- 16 1/4	1,150	- 2,53	.435 round	USA 307-435

©



S.325

S.323

L.326

WORLD CHAMPION

Lucca (I) 2002



S.325 L.326

S.323

LE PAGE® TARGET

(1840-1850)

Mod. S.325 Standard - A percussione
Mod. L.326 Deluxe - A percussione

Replica di pistola da duello fabbricata da Henri Le Page tra il 1840 e il 1850, è caratterizzata dalla canna scodolabile, cromata e satinata esternamente. Particolarmente adatta al tiro di precisione è dotata di stecher e di tacca di mira regolabile in verticale. Il calcio è in noce europeo zigrinato e lucidato a olio. Nella versione Deluxe, tutte le parti presentano una incisione con motivo floreale e la canna è color damasco con rimessi in oro.

LE PAGE® TARGET

(1840-1850)

Mod. S.325 Standard - Percussion model
Mod. L.326 Deluxe - Percussion model

Reproduction of a duelling pistol produced by Henry Le Page between 1840 and 1850, featuring a hook breech barrel, outside chromed and satin finish.

Particularly fit for the precision target shooting, is equipped with set trigger and rear sight with elevation adjustment. The stock is of European walnut, checkered and oil finish.

The Deluxe version, all the metal parts have a scroll engraving, the barrel is rust brown finish colour with gold inlays.

LE PAGE® "MAPLE"

(1840-1850)

Mod. S.323 - A percussione

Versione con calcio di acero. La particolare lucidatura viene eseguita a mano seguendo le antiche tecniche dei maestri artigiani del nord America.

La canna color damasco e l'acciarino satinato color argento vecchio contrastano con il calcio conferendo all'arma una sobria eleganza.

LE PAGE® "MAPLE"

(1840-1850)

Mod. S.323 - Percussion model

Version with fantastic maple grip. The wood finishing is hand made following the old techniques of the North American skilled gunsmiths.

Rust brown finish colour for the barrel and coin colour finish for the lock give a nice contrast with the maple wood and a sober elegance to the pistol.

Mod.	Cal.	Righe Grooves	Passo Twist mm - inches	Lungh. canna Barrel length mm - inches	Lungh. totale Overall length mm - inches	Peso Weight kg - lbs	Misura palla Ball/bullet size	Blocco pallottiere Bullet mould Our code
S.323 - S.325 L.326	.31	7	380 - 1:15	250 - 9 7/8	425 - 16 1/2	1,100 - 2.42	.308 round	USA 307-308
S.323 - S.325 L.326	.36	7	450 - 1:18	260 - 10 1/4	430 - 16 9/16	1,100 - 2.42	.354 round	USA 307-354
S.323 - S.325 L.326	.44	7	450 - 1:18	260 - 10 1/4	430 - 16 9/16	1,050 - 2.31	.435 round	USA 307-435



WORLD CHAMPION

- Madrid (E) 1985
- Camp Perry (USA) 1992
- Warwick (GB) 1996
- Warwick (GB) 1998 (Team)
- Adelaide (AU) 2000
- Lucca (I) 2002 (Team)
- Batesville (USA) 2004
- Bordeaux (F) 2006 (Team)



S.327 L.327

LE PAGE® TARGET

Mod. S.327 Standard - A pietra focaia
Mod. L.327 Deluxe - A pietra focaia

Nata con l'esigenza del tiro di precisione è dotata di stecher e di tacca di mira regolabili. La canna è color damasco e le altre parti in acciaio sono color argento vecchio. L'acciarino è dotato di rullino antifrizione sulla molla della martellina e tutte le sue parti sono finite a specchio. Il calcio in noce europeo è zigrinato nello stesso stile dell'originale.

Nel modello Deluxe, viene messo in rilievo il valore artistico dell'incisione, con finiture e rimessi in oro e argento eseguiti a mano. Nell'acciarino è incisa in argento una conchiglia tipica della fine Settecento.

(1810 c.)



LE PAGE® TARGET

Mod. S.327 Standard - Flintlock model
Mod. L.327 Deluxe - Flintlock model

This excellent pistol produced in conformity with shooter requirements is provided with adjustable single set trigger and rear sight. The lock, provided with a roller frizzen spring is, as are all its component parts, brightly polished. The European walnut stock, is carefully checkered to the style of the original.

Truly a joy to shoot and own, the Deluxe model shows a degree of artistic engraving completed by gold and silver inlays that demonstrate the pistol engraver's art. The lock is personalized by a silver engraved shell, a typical decoration in use in the late 1700's.

(1810 c.)

Mod.	Cal.	Righe Grooves	Passo Twist mm - inches	Lungh. canna Barrel length mm - inches	Lungh. totale Overall length mm - inches	Peso Weight kg - lbs	Misura palla Ball/bullet size	Blocco pallottiere Bullet mould Our code
S./L.327	.44	7	450 - 1:18	266 - 10 1/2	435 - 17 1/16	1,200 - 2.64	.435 round	USA 307-435
S./L.327	.45 smooth	-	-	266 - 10 1/2	435 - 17 1/16	1,200 - 2.64	.464 round	USA 307-464

©





WORLD CHAMPION

Lucca (I) 2002
Bordeaux (F) 2006

S.345 L.345 S.344 L.344



MORTIMER

Mod.S.345 Standard - A pietra focaia
Mod.L.345 Deluxe - A pietra focaia
Mod.S.344 Standard - A percussione
Mod.L.344 Deluxe - A percussione

L'essere citati in termini positivi, a pagina 157 del libro di H. Lee Munson *The Mortimer Gunmakers - 1753-1923*, a proposito della nostra ormai famosa riproduzione del fucile Mortimer, ci ha decisamente inorgoglit; abbiamo quindi accolto i suggerimenti di molti tiratori e riprodotto un modello di una delle più prolifiche famiglie di armaioli, le cui armi erano sinonimo di superba qualità e accuratezza. Le armi originali erano marcate su due linee H.W. MORTIMER & SON LONDON / GUN MAKERS TO HIS MAJESTY e la nostra riproduzione ne ha mantenuto tutte le caratteristiche tecniche e balistiche, a cui si aggiunge la realizzazione delle parti meccaniche con macchine a controllo numerico, che ne garantiscono la qualità esecutiva. La canna, scodolabile e cromata, è perfettamente allineata con la parte superiore del calcio, caratte-

(1810-1840 c.)

rizzato dall'impugnatura a "manico di sega", zigrinato, che assicura al tiratore una presa "costantemente" uguale in modo da rendere la linea di mira più lunga. La bacchetta conica, con puntale in corno appare un dettaglio elegante nel sobrio contesto di una delle più belle repliche sul mercato. La versione Deluxe risulta elegante e preziosa nelle sue incisioni di scuola inglese, copie esatte dell'originale, con finiture e rimessi in oro eseguiti completamente a mano. L'arma è prodotta con calcio in noce europeo selezionato, le parti metalliche presentano una finitura color argento vecchio e la canna è color damasco.

Mod.	Cal.	Righe Grooves	Passo Twist	Lung.h. canna Barrel length	Lung.h. totale Overall length	Peso Weight	Misura palla Ball/bullet size	Blocco pallottiere Bullet mould
			mm - inches	mm - inches	mm - inches	kg - lbs		Our code
S./L.344	.36	7	450 - 1:18	255 - 10 ¹ / ₁₆	400 - 15 ¹ / ₄	1,100 - 2.42	.354 round	USA 307-354
S./L.344	.44	7	450 - 1:18	255 - 10 ¹ / ₁₆	400 - 15 ¹ / ₄	1,000 - 2.20	.435 round	USA 307-435
S./L.345-044	.44	7	450 - 1:18	255 - 10 ¹ / ₁₆	400 - 15 ¹ / ₄	1,000 - 2.20	.435 round	USA 307-435
S./L.345-440	.44 smooth	-	-	255 - 10 ¹ / ₁₆	400 - 15 ¹ / ₄	1,050 - 2.31	.435 round	USA 307-435

MORTIMER

(1810-1840 c.)

Mod. S.345 Standard - Flintlock model
Mod. L.345 Deluxe - Flintlock model
Mod. S.344 Standard - Percussion model
Mod. L.344 Deluxe - Percussion model

Being mentioned with very positive terms, at page 157 of the book written by H. Lee Munson "The Mortimer Gunmakers - 1753-1923", for our famous reproduction of the Mortimer rifle, we became so proud to yield to the suggestions of many shooters to reproduce also a model of pistol of that family which has been surely one of the most prolific gunsmith families producing guns of great quality and accuracy.

The original pistol were marked in two lines H.W. MORTIMER & SON LONDON / GUN MAKERS TO HIS MAJESTY and our reproductions maintained all the technical and ballistic characteristics, with thanks to the production of mechanical parts made with numerical control machines, quality is assured. The breech hook chromed barrel is perfectly aligned with the upper part of the wood, featured with a "saw grip", checkered, that grant the shooter a continous steady grip for the best aiming of the target. The conical ramrod with horn tip gives an elegant detail in the sober contrast of one of the most beautiful replicas on the market. The Deluxe version is enriched with engravings in the style of the English school, with exact copies of the original patterns, with gold inlays on the barrel. The pistol is produced with selected walnut stock, the metal parts are coin finish colour and the barrel is rust brown colour finished.

WORLD CHAMPION

Warwick (GB) 1996 (Team)

S.305
S.306
S.357
S.306 S.305
CHARLES MOORE TARGET

(1800-1840 c.)

 Mod. S.306 - A pietra focaia
 Mod. S.305 - A percussione

Fedele riproduzione di pistola da duello inglese prodotta da Moore in Londra, è caratterizzata dalla canna scodolabile, cromata e satinata esternamente. Il calcio, in noce, è zigrinato e lucidato a olio. Prodotta con acciarino e fornimenti color argento vecchio, è dotata di stecher regolabile.

MLAIC
CHARLES MOORE TARGET

(1800-1840 c.)

 Mod. S.306 - Flintlock model
 Mod. S.305 - Percussion model

A faithful reproduction of an English duelling pistol, originally created by Charles Moore in London, featuring a hook breech barrel, outside chromed and satin finish. The stock is of walnut, checkered and oil finish. Produced with lock and furniture coin finish colour, it is provided with adjustable single set trigger.

S.357
CARLETON
UNDERHAMMER TARGET
 (1850 c.)

Mod. S.357

Fra i vari costruttori di armi con il cane inferiore, Michael Carleton di Haverhill, nel New Hampshire, fu quello che realizzò un modello che meccanicamente riuscì a prevalere sugli altri grazie al movimento rettilineo del cane, con una corsa parallela all'asse della canna. Il luminello è avvitato orizzontalmente sul portalumino posto nella parte inferiore della bascula, e la molla del cane funge anche da paragrilletto. Le parti di scorrimento sono rettificate in modo da ridurre gli attriti: il risultato è uno scatto molto sensibile e regolabile, pur in assenza di stecher. L'arma, estremamente bilanciata, è realizzata con canna color damasco e completata da un'impugnatura che, sagomata a manico di sega, garantisce una presa salda e sicura.

MLAIC
CARLETON
UNDERHAMMER TARGET
 (1850 c.)

Mod. S.357

Among the various guns manufacturers of under hammer, Michael Carleton of Haverhill, New Hampshire, made the model that prevailed over other models thanks to the liner movement of the hammer having a parallel motion to the barrel axis. The nipple is horizontally screwed over the drum placed in the under part of the frame and the main hammer spring looks like a trigger guard. The sliding moving parts are carefully designed to reduce their friction: the result is a very moderate crisp pull, even without a set trigger. This very well balanced gun is made with rust brown finish colour barrel, completed with a saw handle stock, providing a firm and natural grip.

Mod.	Cal.	Righe Grooves	Passo Twist		Lungh. canna Barrel length		Lungh. totale Overall length		Peso Weight		Misura palla Ball/bullet size	Blocco pallottiere Bullet mould Our code
			mm	inches	mm	inches	mm	inches	kg	lbs		
S.305	.36	7	380	1-15	280	11 ¹ / ₁₆	430	16 ⁹ / ₁₆	1,150	2.53	.354 round	USA 307-354
S.305 - S.306	.45	12	450	1-18	280	11 ¹ / ₁₆	430	16 ⁹ / ₁₆	1,100	2.42	.445 round	USA 307-445
S.306	.44 smooth	-	-	-	280	11 ¹ / ₁₆	430	16 ⁹ / ₁₆	1,100	2.42	.435 round	USA 307-435
S.357	.36	7	450	1-18	215	8 ¹ / ₂	400	15 ¹ / ₄	1,140	2.51	.354 round	USA 307-354

©





S.360

S.361

S.360 S.361

CONTINENTAL DUELLING

Mod. S.360 - A percussione
Mod. S.361 - A pietra focaia

Riproduzione di una tipologia di pistola da duello di stile mitteleuropeo dalle linee semplici ed essenziali.

Disponibile sia nella versione a percussione sia in quella a pietra focaia, rappresenta la scelta ideale per un primo approccio al tiro ad avancarica, grazie all'ottimo rapporto qualità/prezzo. La canna ottagonale è brunita nella colorazione marrone; la tacca di mira e il mirino sono regolabili in orizzontale; l'accia-

rino evidenzia la finitura color tartaruga; il calcio è in legno di noce con impugnatura zigrinata; il grilletto è regolabile.

La Continental Duelling è disponibile anche in coppia, contenuta in un cofanetto di legno con rivestimento interno color ocra. La coppia a percussione è corredata di cacciavite e chiave luminello con impugnatura di legno color ebano, portaolio in ottone e scatola portacapsule. Assieme alla coppia a pietra trovano posto il cacciavite, il pan primer, il portaolio e una scatola di ottone.

(1810-1850)

CONTINENTAL DUELLING

Mod. S.361 - Flintlock model
Mod. S.360 - Percussion model

Mid Europe style duelling pistol, featuring simple and essential lines. Thanks to the good price/quality relation, it represents the ideal choice for the first muzzle loading target shooter. The barrel is rust brown colour finish, the rear sight and the front sight are windage adjustable, the lock has a case hardened colour finish; pistol grip checkered stock; adjustable trigger. The Continental Duelling pistol is

(1810-1850)

available also as a pair into a wood case with okra colour lining. The percussion pair is equipped with screw driver and nipple wrench with ebony colour wood handle, brass oilcan and caps box. The case with the flintlock pistols pair contains the screw driver, the pan primer, the oilcan and a brass small box.

Mod.	Cal.	Righe Grooves	Passo Twist mm - inches	Lungh. canna Barrel length mm - inches	Lungh. totale Overall length mm - inches	Peso Weight kg - lbs	Misura palla Ball/bullet size	Blocco pallottiere Bullet mould Our code
S.360-S.361	.45	12	450 - 1:18	280 - 11 ¹ / ₈	415 - 16 ¹ / ₈	1,000 - 2.20	.445 round	USA 307-445

©



S.347

S.349

WORLD CHAMPIONSHIP
 Adelaide (AU) 2000 - Bronze (Team)
 Lucca (I) 2002 - Silver (Team)



S.347
ROGERS & SPENCER
"PEDERSOLI" TARGET
 (1863-1865)

Mod. S.347

Bellissima riproduzione del famoso revolver Rogers & Spencer, ove tutte le parti più importanti sono realizzate con macchine a controllo numerico. L'assemblaggio è realizzato da maestri artigiani che garantiscono ottimi scatti per le migliori performance. Le parti in metallo sono brunite antiriflesso; il cilindro, come nelle versioni "Custom", è dotato di fascia lucida che riduce gli attriti durante la rotazione. La tipica impugnatura, in noce, la rende particolarmente adatta per il tiro di precisione.

S.347
ROGERS & SPENCER
"PEDERSOLI" TARGET
 (1863-1865)

Mod. S.347

Born to win! Wonderful reproduction of the famous Rogers & Spencer revolver with all critical parts made on numerical computer controlled machines. Assembly is effected by master gunsmiths to ensure excellent shot release for the best performances. All metal parts are "matt" blued. Like the custom made version, the cylinder is provided with a glossy band that reduces friction during rotation. Its typical walnut grip is perfect for target shooting requirements.

S.349
REMINGTON PATTERN
"PEDERSOLI" TARGET
 (1863-1875)

Mod. S.349

Dopo i successi ottenuti dal modello Rogers & Spencer "Pedersoli" Target, abbiamo introdotto, su specifica richiesta di alcuni tiratori, questo nuovo revolver da tiro, prodotto sul modello Remington. I materiali impiegati sono di ottima qualità, così come le caratteristiche balistico-costruttive della canna, del tamburo e dei meccanismi di scatto. L'arma è stata appositamente "customizzata" dai nostri artigiani tiratori, con l'intento di conferire un'ottima funzionalità, sin dal primo utilizzo. La canna antiriflesso, il tamburo antiusura e il passo di rigatura sono stati attentamente studiati per dare al tiratore quella chance in più nell'attività agonistica.

S.349
REMINGTON PATTERN
"PEDERSOLI" TARGET
 (1863-1875)

Mod. S.349

After the success obtained in the target shooting with Rogers & Spencer "Pedersoli" Target model and under specific requirements from shooters, we introduced this new target revolver, produced on the Remington model. The materials used are of the best quality, enhancing the ballistic characteristics of the barrel, of the cylinder and of the trigger set mechanism. The gun has been expressly "customized" by our crafts-workers and shooters, with the purpose to give the gun a good functionality with the very first use. The non-reflecting barrel, the anti-wear cylinder and the rifling twist have been designed to give the shooter the best chance.

Mod.	Cal.	Righe Grooves	Passo Twist mm - inches	Lungh. canna Barrel length mm - inches	Lungh. totale Overall length mm - inches	Peso Weight kg - lbs	Misura palla Ball/bullet size	Blocco pallottiere Bullet mould Our code
S.347	.44	7	450 - 1:18	190 - 7 1/2	340 - 13 3/8	1,300 - 2,86	.454 round	USA 307-454
S.349	.44	7	450 - 1:18	200 - 7 7/8	350 - 13 7/16	1,230 - 2,71	.454 round	USA 307-454

© A.S.





S.310 S.313

KENTUCKY

(1750-1850 c.)

Mod. S.310 - A pietra focaia
Mod. S.313 - A percussione

Compatta, solida, perfettamente impugnabile, è la pistola americana tipica della Guerra d'Indipendenza e dei pionieri dell'Ovest. Arma di notevole precisione con canna in acciaio, brunita, e calcio in noce.

KENTUCKY

(1750-1850 c.)

Mod. S.310 - Flintlock model
Mod. S.313 - Percussion model

With a perfect grip and accuracy of firing, this pistol was the classical American pistol during the war of Independence and of the western pioneers. The octagonal rifled barrel is of blue finished steel and the stock is made from walnut.

S.312 S.311

KENTUCKY "MAPLE"

(1750-1850 c.)

Mod. S.312 - A pietra focaia
Mod. S.311 - A percussione

Superba versione in acero, essenza di legno utilizzata dai pionieri e lucidata secondo antiche formule degli armaioli americani. La canna è color marrone, l'acciarino è satinato e i fornimenti sono in ottone.

KENTUCKY "MAPLE"

(1750-1850 c.)

Mod. S.312 - Flintlock model
Mod. S.311 - Percussion model

A superb version with a maple stock, traditional wood as used by the pioneers and finished according to the original formulas of the American gunsmiths. The barrel is rust brown colour finished, the lock is coin colour finished and with brass furniture.

Mod.	Cal.	Righe Grooves	Passo Twist mm - inches	Lungh. canna Barrel length mm - inches	Lungh. totale Overall length mm - inches	Peso Weight kg - lbs	Misura palla Ball/bullet size	Blocco pallottiere Bullet mould Our code
S.310 - S.311	.45	12	450 - 1:18	264 - 10 ³ / ₈	390 - 15 ⁵ / ₈	1,050 - 2.31	.445 round	USA 307-445
S.312 - S.313								
S.310 - S.311	.50	12	450 - 1:18	264 - 10 ³ / ₈	390 - 15 ⁵ / ₈	1,150 - 2.53	.490 round	USA 307-490
S.312 - S.313								
S.310 - S.311	.54	7	600 - 1:23	264 - 10 ³ / ₈	390 - 15 ⁵ / ₈	1,100 - 2.42	.535 round	USA 307-535
S.312 - S.313								





S.317



S.353



S.354

S.316 S.317

BOUNTY

(1750-1850 c.)

Mod. S.316 - A pietra focaia
Mod. S.317 - A percussione

Fu la pistola dei *Bounty Hunters*, che sfruttavano la sua lunga canna per aumentarne la precisione a lunghe distanze. La canna è in acciaio, brunita e il calcio è in noce.

BOUNTY

(1750-1850 c.)

Mod. S.316 - Flintlock model
Mod. S.317 - Percussion model

This pistol, because of its long barrel that could assure better accuracy of firing at long distance, was the favourite one of the Bounty Hunters. Blue steel octagonal barrel and walnut stock.

S.353 S.354

NAVY MOLL

(1750-1850 c.)

Mod. S.353 - A percussione
Mod. S.354 - A pietra focaia

Elegante pistola con calcio in acero, colorato e lucidato seguendo gli stessi procedimenti adottati dagli armaioli americani tra la fine Settecento e l'inizio dell'Ottocento. La canna, in acciaio, è brunita e l'acciarino "tartarugato". Una coccia in ottone alla base dell'impugnatura conferisce all'arma un tocco di originalità.

NAVY MOLL

(1750-1850 c.)

Mod. S.353 - Percussion model
Mod. S.354 - Flintlock model

Elegant pistol with maple stock coloured and finished according to the original formulas of the American gunsmiths between the late 1700s and the early 1800s. The barrel is made of blued steel, the lock is case hardened. The brass butt stock gives originality to the pistol.

Mod.	Cal.	Righe Grooves	Passo Twist mm - inches	Lungh. canna Barrel length mm - inches	Lungh. totale Overall length mm - inches	Peso Weight kg - lbs	Misura palla Ball/bullet size	Blocco pallottiere Bullet mould Our code
S.316 - S.317	.45	12	450 - 1:18	415 - 16 ¹ / ₈	540 - 21 ¹ / ₄	1,400 - 3.08	.445 round	USA 307-445
S.316 - S.317	.50	12	450 - 1:18	415 - 16 ¹ / ₈	540 - 21 ¹ / ₄	1,600 - 3.52	.490 round	USA 307-490
S.353 - S.354	.45	12	450 - 1:18	264 - 10 ³ / ₈	390 - 15 ³ / ₈	1,050 - 2.31	.445 round	USA 307-445





S.320

HARPER'S FERRY

(1806-1808)

Mod. S.320

La Harper's Ferry fu la prima pistola a pietra focaia ordinata dal Governo americano per l'equipaggiamento delle truppe della marina. Il suo nome è dato da uno dei più pittoreschi villaggi della Virginia, ove erano stati installati un'armeria e un arsenale che vennero distrutti durante la Guerra di Secessione, senza essere più ricostruiti. Il calcio è in noce, con parti in ottone perfettamente incassate. La canna è cromata e satinata esternamente e l'acciarino è color tartaruga.

HARPER'S FERRY

(1806-1808)

Mod. S.320

The Harper's Ferry was the first flintlock pistol requested by the American Government to equip the Navy.

It is named after one of the most picturesque villages in Virginia, where an armoury and an arsenal were built, then destroyed during the Civil War, without ever being rebuilt. The stock is made from walnut with brass garnitures. The barrel is chromed and glazed outside. Case hardened lock.

S.328

QUEEN ANNE

(1730 c.)

Mod. S.328

Bellissima copia di pistola a pietra focaia in uso in Inghilterra tra la fine del 1600 e i primi del 1700 durante il regno della regina Anna, da cui il nome. Come gli originali, questa replica è caratterizzata da una cocchia con mascherone grottesco alla base dell'impugnatura in noce. La canna è cromata e satinata esternamente, l'acciarino è temperato argento vecchio e i particolari sono in ottone.

QUEEN ANNE

(1730 c.)

Mod. S.328

A true copy of the famous English pistol that came into use in England between the end of 1600 and the beginning of 1700, during the Reign of Queen Anne, hence the name.

As with the originals, this reproduction is characterized by a grotesque metal mask under the buttstock. Chromed barrel, glazed outside, coin finish colour lock. Stock in walnut. Polished brass parts.

S.329

QUEEN ANNE "BRASS"

(1730 c.)

Mod. S.329

Versione con canna in ottone, che ne esalta la forma regale. Completata con cofanetto o pannello è ideale per un regalo speciale.

QUEEN ANNE "BRASS"

(1730 c.)

Mod. S.329

Version with brass barrel, which emphasises its regal style. Offered with case or framed panel, becoming ideal for a special gift.

Mod.	Cal.	Righe Grooves	Passo Twist mm - inches	Lungh. canna Barrel length mm - inches	Lungh. totale Overall length mm - inches	Peso Weight kg - lbs	Misura palla Ball/bullet size	Blocco pallottiere Bullet mould Our code
S.320	.58	7	1.200 - 1:48	255 - 10 ¹ / ₁₆	410 - 16 ¹ / ₈	1,150 - 2.53	.575 round	USA 306-575
S.328 - S.329	.50 smooth	-	-	198 - 7 ⁷ / ₁₆	330 - 13	1,000 - 2.20	.490 round	USA 307-490



S.355

AN IX (1803-1807)

Mod. S.355
 Famosa pistola per la Cavalleria napoleonica ispirata al precedente Modello 1763-66, fu realizzata accorciando la canna, variando la curva dell'impugnatura e adottando il collaudato sistema dell'acciarino del moschetto An IX. Dal 1803 al 1807 ne furono fabbricate 33.000 paia, quasi tutte impiegate durante le campagne militari dell'Impero. La nostra riproduzione, rigorosamente fedele all'originale, monta i fornimenti in ottone, come il classico lungo bocchino di tenuta della canna, il guardamano, il fregio e la cocchia alla base dell'impugnatura.

AN IX (1803-1807)

Mod. S.355
 Famous cavalry pistol of the Napoleon period, inspired by the previous Model 1763-66. This pistol has a shorter barrel, the hand grip shape has been varied and the crafted lock system of the An IX musket was adopted in its scale down version. From 1803 to 1807 about 33.000 pistols "pair" have been produced, all of them used during the Empire military battles. Our reproduction, like the original model, features brass garnitures: the long front band, the trigger guard and the butt cap.

S.356

AN XIII (1806-1819)

Mod. S.356
 Fabbricata in 150.000 paia, è ispirata al Modello 1786 in dotazione alla Marina e costituisce la versione semplificata del Modello An IX: il bocchino venne sostituito da una fascetta fissata alla vite anteriore della controcartella, e la calciatura accorciata, così da renderla più maneggevole. La nostra riproduzione, come il modello originale, presenta i fornimenti in ottone e, come il Modello An IX, si pone come una magnifica arma per essere impiegata in molte e importanti rievocazioni storiche.

AN XIII (1806-1819)

Mod. S.356
 Produced in 150.000 pistols "pair", it is inspired by the Model 1786 equipping the Navy and it is the simplified version of the Model An IX. Changed the front band that it is fixed with a screw to the side lock, the shortened stock gets it more handy. Our reproduction, like the original model, features brass garnitures and like the An IX model is a magnificent gun for many and important re-enactment events.

Mod.	Cal.	Righe Grooves	Passo Twist mm - inches	Lungh. canna Barrel length mm - inches	Lungh. totale Overall length mm - inches	Peso Weight kg - lbs	Misura palla Ball/bullet size	Blocco pallottiere Bullet mould Our code
S.355 - S.356	17,5 mm	-	-	210 - 8 1/4	350 - 13 7/8	1,350 - 2,97	.675 round	USA 306-675





L.342



S.351



S.342



C.972



C.957

DERRINGER RIDER

- Mod. S.342 - Bianca
- Mod. L.342 - Bianca Deluxe
- Mod. S.351 - Tartarugata

- Mod. C.955 - Bianca in cofanetto
- Mod. C.956 - Bianca Deluxe in cofanetto
- Mod. C.957 - Tartarugata in cofanetto

- Mod. C.972 - Bianca in cofanetto doppio
- Mod. C.973 - Tartarugata in cofanetto doppio
- Mod. C.974 - Bianca Deluxe in cofanetto doppio

(1860-1863)
Riproduzione della Remington Rider Single Shot Derringer, altrimenti conosciuta come "Parlor Pistol", la più piccola delle pistole prodotte dalla Remington tra il 1860 e il 1863 in soli duecento esemplari, in calibro .17" (4,3 mm). Realizzata in acciaio, è disponibile nelle versioni con finitura bianca e con finitura tartaruga. La versione Deluxe, con finitura bianca, è caratterizzata da una ricca incisione con motivo floreale; sull'impugnatura invece è presente una serie di solchi incrociati che richiamano l'effetto di una zigrinatura. Tutte le versioni sono presentate anche in cofanetto in legno, completo di scatola portacapsule in ottone, per una o per due pistole. Il funzionamento prevede soltanto l'uso della capsula e di un pallino calibro 4,3 mm da collocare all'interno del luminello estraibile.

DERRINGER RIDER

- Mod. S.342 - White
- Mod. L.342 - White Deluxe
- Mod. S.351 - Case hardened

- Mod. C.955 - White with wooden case
- Mod. C.956 - White Deluxe with wooden case
- Mod. C.957 - Case hardened with wooden case

- Mod. C.972 - White with double wooden case
- Mod. C.973 - Case hardened with double wooden case
- Mod. C.974 - White Deluxe with double wooden case

This is a reproduction of the extremely rare Remington Rider Single Shot Derringer pistol of which only about 200 were produced 1860-1863.

(1860-1863)

Small pistols suitable for indoor practice were called "Parlor Pistols". The pistol is of steel construction, available with polished white or case hardened finish as well as having an optional wood case available for one or for two pistol, which has brass box for caps. The Deluxe version, whit white finish, features a rich scroll engraving. On the grip there are a series of crossed lines giving a checkering effect. Like the original, the pistol fires a .17 inch (4,3 mm) ball using only a percussion cap and no black powder charge. For short range it is powerful, accurate and fairly quiet, making it suitable for indoor use. A .17" (4,3 mm) ball is placed into the breech plug small tube (which is capped) inserted against the barrel. The hammer fires a #11 cap which expels the ball.

Mod.	Cal.	Righe Grooves	Passo Twist mm - inches	Lungh. canna Barrel length mm - inches	Lungh. totale Overall length mm - inches	Peso Weight kg - lbs
S/L.342 - S.351	4,3 mm	10	450 - 1:18	52 - 2 ¹ / ₁₆	120 - 4 ⁷ / ₁₆	0,155 - 0,34



L.330

C.980



S.330

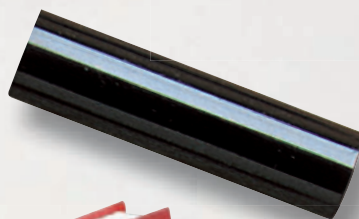

S.339

C.952

S.330 L.330

DERRINGER LIEGI

(1850 c.)

Mod. S.330 Standard
Mod. L.330 Deluxe

Fra i numerosi modelli di Derringer questo fu certamente fra i più popolari dell'epoca. Questa piccola ma efficace arma, di facile impugnatura, era utilizzata da tiratori, avventurieri, nobili e gentiluomini. La canna in acciaio, brunita, è smontabile; il grilletto a scomparsa si riposiziona pronto a funzionare quando il cane viene armato. La bascula è color tartaruga e il calcio è in noce. La bascula finemente incisa, secondo i modelli originali, e il metallo color argento vecchio, sono le caratteristiche principali del modello Deluxe.

DERRINGER LIEGI

(1850 c.)

Mod. S.330 Standard
Mod. L.330 Deluxe

This famous Derringer model is faithfully reproduced to provide virtually every feature of the original. Small enough to fit in a vest pocket, it is a great addition to any collection. The frame is colour case hardened and stock is made from walnut. Interesting details, such as the removable rifled blue barrel and the folding trigger, make it one of the better example of this type. The accurate engraving executed in compliance with the original models, as well as the coin colour finished metal parts, are the main characteristics of the Deluxe version.

S.339

DERRINGER LIEGI POCKET

(1850 c.)

Mod. S.339

Versione di pistola Derringer prodotta con canna tondo-conica. Anche in questo modello la canna si svita per il caricamento, rendendo inutile l'uso di ogni tipo di bacchetta.

USA 351

COFANETTO LIBRO

USA 351

Cofanetto a forma di libro dal titolo LAW FOR SELFDEFENCE, con interno in velluto per accogliere la pistola Derringer Liegi nei modelli Deluxe (C.953) oppure standard (C.952).

USA 366

COFANETTO LEGNO

USA 366

Cofanetto in legno per la pistola Derringer Liegi nei modelli standard (C.979) oppure Deluxe (C.980).

DERRINGER LIEGI POCKET

(1850 c.)

Mod. S.339

Version of Derringer pistol, featuring a round cannon style barrel. Like the Liegi model, the barrel unscrews for loading making any sort of ramrod unnecessary.

BOOK CASE

USA 351

A case looking like a book with a title "Law for self-defence", inside velvet lining to lodge Derringer Liegi pistol in the standard (C.953) or the standard (C.952) models.

WOOD CASE

USA 366

Wood case for the Derringer Liegi pistol in the standard (C.979) or the Deluxe (C.980) models.

Mod.	Cal.	Righe Grooves	Passo Twist mm - inches	Lungh. canna Barrel length mm - inches	Lungh. totale Overall length mm - inches	Peso Weight kg - lbs	Misura palla Ball/bullet size	Blocco pallottiere Bullet mould Our code
S./L.330	.44	8	450 - 1:18	60 - 8 ¹ / ₈	165 - 6 ¹ / ₂	0,190 - 0.42	.451 round	USA 307-451
S.339	.36	7	380 - 1:15	100 - 3 ⁹ / ₁₆	200 - 7 ¹ / ₈	0,230 - 0.51	.362 round	USA 307-362



S.335



S.337

S.335

ZIMMER

(1850 c.)

Mod. S.335

Replica di pistola belga, con calcio in noce caratterizzato da scanalature e da una tipica cocchia in acciaio. Realizzata con canna tonda brunita e bascula color tartaruga, è dotata di mirino e tacca di mira.

ZIMMER

(1850 c.)

Mod. S.335

Reproduction of Belgian pistol that features an walnut stock with traditional fluted grip, enriched with a typical metal buttcap. Provided with front and rear sights, it is produced with round barrel and colour case hardened frame.

S.337

SALOON

(1850 c.)

Mod. S.337

Replica di pistola belga a percussione caratterizzata dalla posizione del luminello che permette una facile e veloce accensione. La canna tonda è brunita e la bascula è color tartaruga. È dotata di tacca di mira e mirino.

SALOON

(1850 c.)

Mod. S.337

Copy of a Belgian pistol with nipple positioned in order to assure an extremely fast ignition. The frame and hammer are colour case hardened. It is provided with front and rear sights.

Mod.	Cal.	Righe Grooves	Passo mm - inches	Lungh. canna Barrel length mm - inches	Lungh. totale Overall length mm - inches	Peso Weight kg - lbs	Misura palla Ball/bullet size	Blocco pallottiere Bullet mould Our code
S.335	4,5 mm	10	250 - 1:10	185 - 7 ¹ / ₁₆	300 - 11 ⁹ / ₁₆	0,500 - 1.10	4,5 mm	-
S.337	.36	7	380 - 1:15	215 - 8 ¹ / ₂	330 - 13	0,700 - 1.54	.354 round	USA 307-354
S.337	4,5 mm	10	250 - 1:10	185 - 7 ¹ / ₁₆	300 - 11 ⁹ / ₁₆	0,500 - 1.10	4,5 mm	-

SPECIAL EDITIONS

Special Editions

La ricerca di una godibile espressione pittorica, scultorea o grafica conduce l'artista a creare opere in cui riversare, sempre in misura maggiore e completa, la passione, l'abilità e il genio creativo. Il fruitore di tali risultati è solitamente il cultore della bellezza e della unicità, ma anche colui che comprende il pensiero dell'artista e ne percepisce le emozioni.

L'incisione sui metalli, arte di antichissima memoria, non si discosta molto dalla pittura; con i suoi giochi d'ombra e con la collocazione spazio-temporale dei soggetti, permette di vivere la stessa sensazione che può infondere un'opera creata con un pennello e con dei colori.

La **Davide Pedersoli**, sempre attenta alle più nobili espressioni artistiche, è orgogliosa di presentare alcuni modelli impreziositi da gradevoli ed eleganti incisioni con armoniosi motivi floreali o con soggetti di ispirazione western o venatoria. Il risultato finale consente di ammirare delle creazioni in cui l'avanzata tecnologia armiera di casa Pedersoli si amalgama con l'intensa espressione artistica di maestri incisori.

Sulla canna può fare bella mostra di sé qualche bordino d'oro niellato in prossimità della volata e della culatta. Con rimessi in oro o argento può essere anche il marchio della Davide Pedersoli e il nome del futuro proprietario.

La nostra azienda, riservandosi la possibilità di concordare il costo e i tempi di consegna, sarà lieta di accogliere le richieste di incisioni personalizzate, da realizzare sul modello di arma prescelto.

Possedere e collezionare armi così allestite vuol dire sottolineare un approccio a un'opera d'arte come si farebbe con un dipinto, una scultura, un gioiello. In fondo, quelle che oggi chiamiamo riproduzioni potranno diventare tra qualche decennio gli "originali della seconda generazione", da apprezzare per il loro prestigio e per la loro eleganza.

Special Artistic Editions

*When artists seek suitable themes for their productivity, be it in pictures, sculptures or music, they are guided both consciously and instinctively by self-confidence in their abilities, by stamina and perseverance, and by the irrepressible need to create. The ancient and demanding arts of ornamenting metals by engraving and ancillary techniques are not so very far removed from those of drawing and painting; their play of light and shadow and their harmonious relationships to the surrounding space often induce pleasurable sensations in the viewer not unlike those engendered by a good pen or pencil drawing and by the measured hues of a quality watercolour or oil painting. As sons and daughters of our homeland and heirs to its edifying traditions, we at **Davide Pedersoli** are always keenly alive to fine representational art and outstanding craftsmanship, and hence take unusual pleasure in presenting the enrichment of several of our models by meticulous, elegant and personalised engraving. Such products celebrate the blending of our world-class firearms technology with the visions and tangible creations of world-class master artisans.*

For about three centuries of firearms history, muzzles and breech-barrels have acquired grace, distinction and character when highlighted by borders of inlaid gold. The Davide Pedersoli mark can be lined in gold or silver, and the new owner's engraved name can stand out in glowing golden permanence. On request, special scenes and subjects can be applied to most parts of nearly all our products. We would be pleased to submit estimates of cost and delivery times upon receipt of your expression of interest and a description of your personal requirements. Collecting and preserving such one-of-a-kind firearms is, after all, much like owning and caring for paintings, sculptures, etchings, engravings, precious stones. And in a few years, today's replicas may well be precious 'Originals of the Second Epoch'!
Do please let us have your views about this initiative via the usual channels.

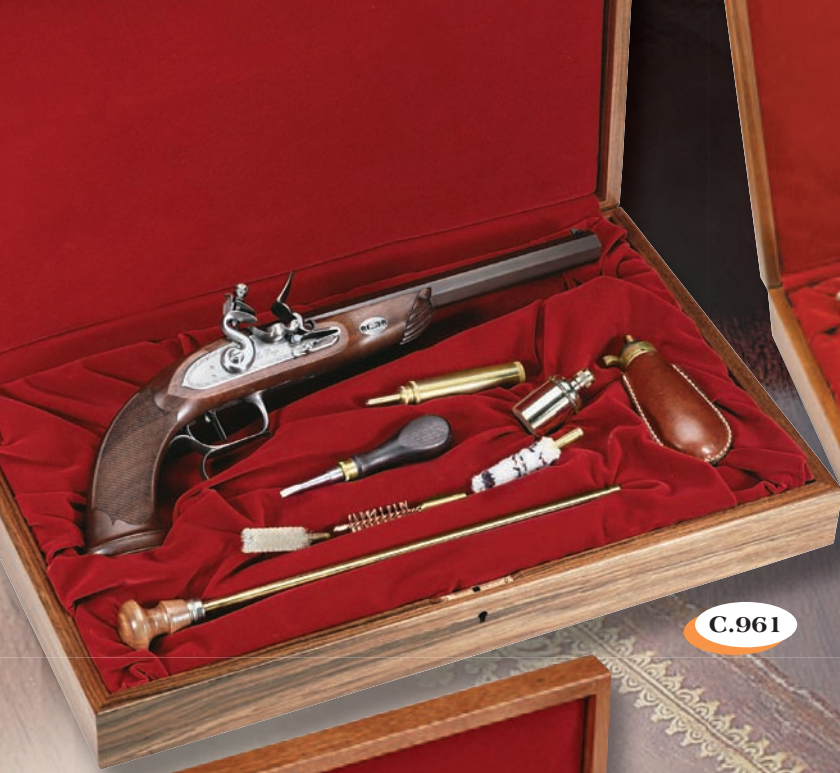

C.961



C.967



C.977



C.964



C.947



C.998



C.994



C.990

PISTOLE IN COFANETTO

La consuetudine di collocare le armi all'interno di un cofanetto era motivata principalmente dalla possibilità di un facile trasporto. Se si trattava di un corredo da viaggio, per esempio, venivano curate le dimensioni dell'astuccio e degli scomparti che ospitavano l'arma e gli accessori. Un corredo da tiro o da duello, a parte il fatto di potere ospitare due pistole, era ancora più curato nella dotazione degli accessori e poteva contenere anche la pinza fondipalle, la fustella per le pezuole e alcune parti di ricambio come viti, luminelli o molle dell'acciarino. Il grado di eleganza e di finitura dei cofanetti, commissionati direttamente all'armaiolo di fiducia e realizzati quasi sempre in legno pregiato, quali il mogano, potevano variare in funzione del grado sociale del proprietario o della fama dello stesso armaiolo. Il fascino e l'eleganza delle pistole in cofanetto rimangono ancora oggi immutati: un motivo in più per collezionarle, per poterle esporre e raccontare antiche pagine di storia armiera.

PISTOLS SET CASE

From the beginning of firearms history it was customary to store the gun in a fitted case which equalled the quality of the gun itself. Such a case protected the gun during rough travel conditions as well as providing safe storage in the home or campground. Cases provided a protective snug fit for the gun plus places for various other items such as bullets, powder flask, caps container, oilcan, screwdriver, nipple wrench and other items required by the owner. Some cases made for twin duelling pistols could have extra items which would be needed during a duel such as bullet mould, patches, hollow punch and spare parts such as screws, nipples and lock springs. The cases elegance and their finishing grade was usually ordered directly from the gunsmith and often made with expensive wood and would vary according to the social grade of the owner or by the gunsmith's fame. The glamour and elegance of displaying pistols in cases are still immutable: one reason more to collect them, to display them and to show viewers the antique gunsmithing history.

MODELLI DISPONIBILI / MODELS AVAILABLE:

Modello / model	Cal.	Code	Modello / model	Cal.
C.947 SET 2 CONTINENTAL DUELLING a percussione / percussion model (S.360)	.45	C.983 MORTIMER DELUXE a percussione / percussion model (L.344)		.36 - .44
C.948 SET TEXAS a percussione / percussion model (NAVY MOLL pistol + Bowie knife)	.45	C.984 MORTIMER DELUXE a pietra focaia / flintlock model (L.345)		.44 - .44 smooth
C.949 SET 2 CONTINENTAL DUELLING a pietra focaia / flintlock model (S.361)	.45	C.985 SET 2 MORTIMER a percussione / percussion model (S.344)		.36 - .44
C.960 LE PAGE® a percussione / percussion model (S.325)	.31 - .36 - .44	C.986 SET 2 MORTIMER a pietra focaia / flintlock model (S.345)		.44 - .44 smooth
C.961 LE PAGE® a pietra focaia / flintlock model (S.327)	.44 - .45 smooth	C.987 SET 2 MORTIMER DELUXE a percussione / percussion model (L.344)		.36 - .44
C.962 LE PAGE® DELUXE a pietra focaia / flintlock model (L.327)	.44 - .45 smooth	C.988 SET 2 MORTIMER DELUXE a pietra focaia / flintlock model (L.345)		.44 - .44 smooth
C.963 LE PAGE® DELUXE a percussione / percussion model (L.326)	.31 - .36 - .44	C.989 MANG IN GRAZ (S.341)		.38 - .44
C.964 SET TEXAS a pietra focaia / flintlock model (NAVY MOLL pistol + Bowie knife)	.45	C.990 MANG IN GRAZ DELUXE (L.341)		.38 - .44
C.965 SET 2 LE PAGE® a percussione / percussion model (S.325)	.31 - .36 - .44	C.991 SET 2 MANG IN GRAZ (S.341)		.38 - .44
C.966 SET 2 LE PAGE® a pietra focaia / flintlock model (S.327)	.44 - .45 smooth	C.992 SET 2 MANG IN GRAZ DELUXE (L.341)		.38 - .44
C.967 SET 2 LE PAGE® DELUXE a percussione / percussion model (L.326)	.31 - .36 - .44	C.993 KUCHENREUTER (S.300)		.38 - .44
C.968 SET 2 LE PAGE® DELUXE a pietra focaia / flintlock model (L.327)	.44 - .45 smooth	C.994 KUCHENREUTER DELUXE (L.300)		38 - .44
C.977 KENTUCKY a percussione / percussion model (S.313)	.45 - .50 - .54	C.995 SET 2 KUCHENREUTER (S.300)		38 - .44
C.978 KENTUCKY a pietra focaia / flintlock model (S.310)	.45 - .50 - .54	C.996 SET 2 KUCHENREUTER DELUXE (L.300)		38 - .44
C.981 MORTIMER a percussione / percussion model (S.344)	.36 - .44	C.998 PISTOLA AN IX (S.355)		17,5 mm
C.982 MORTIMER a pietra focaia / flintlock model (S.345)	.44 - .44 smooth	C.999 PISTOLA AN XIII (S.356)		17,5 mm



S.235 L.235



BRISTLEN A MORGES®

**Mod. S.235 Standard
Mod. L.235 Deluxe**

Questa perfetta replica del fucile svizzero prodotto da Marc Bristlen tra il 1839 e il 1860, nella città di Morges, può senza dubbio essere definita la personificazione dell'eleganza e della qualità.

Disponibile sia nella versione standard, con parti in acciaio color tartaruga, sia nella versione Deluxe, arricchito da incisioni sull'acciarino, sul fregio e sulle parti ornamentali satinata. Sulla canna è riportata la scritta in argento BRISTLEN A MORGES. Il calcio, in noce selezionato, è lucidato a olio.

Munito di stecher a doppia fase, di grande precisione meccanica, con possibilità di regolazione della sensibilità di tiro

sino a 60 g grazie al suo sistema particolare di molle e completato da diottra regolabile in verticale e orizzontale, è particolarmente adatto per il tiro di precisione a 50 metri. L'arma viene corredata di pomolo in legno appoggia mano e salvabocca in calibro .44. Questa riproduzione, a causa del lavoro artigianale di alto livello, è disponibile solo in piccole quantità, e pertanto, si suggerisce di prenotarla con preavviso.

(1845 c.)

BRISTLEN A MORGES®

**Mod. S.235 Standard
Mod. L.235 Deluxe**

This replica of a Swiss target rifle is the perfect embodiment of elegance and quality. It authentically reproduces in every detail, springs, screws, sights, included in the original gun produced by Marc Bristlen between 1839 and 1860, in the town of Morges. It is produced both in standard with colour case hardened lock and fittings, and Deluxe version enriched with engravings on coin finish colour lock and fittings. The barrel is incised BRISTLEN A MORGES, highlighted in silver characters. The oil finished stock is, for both versions, of the finest walnut. Particular attention has been given to

(1845 c.)

the lock where all parts work together in perfect harmony.

It is provided with vertically and horizontally adjustable Creedmoor sight and has a double phase set trigger adjustable for weight and minimum trigger pull, thanks to its particular spring system can be adjusted down to 0.13 lbs (60 g). The gun is equipped with palmrest knob and with a false muzzle .44 caliber. It is optimised for the 50 yards shooting matches.

This replica because of the particularly high quality artistic work, is produced only in limited quantities to order.



Palm rest **USA 660**

S.250

L.234-L.235

S.234-S.235

WORLD CHAMPION

- Pforzheim (D) 1989
- Leusden (NL) 1990
- Camp Perry (USA) 1992 (Team)
- Warwick (GB) 1996 (Team)
- Warwick (GB) 1998 (Team)
- Batesville (USA) 2004
- Bordeaux (F) 2006

S.234 L.234

WAADTLÄNDER

(1845 c.)

Mod. S.234 Standard
Mod. L.234 Deluxe

Versione, del tutto simile al modello Bristlen A Morges di cui conserva le caratteristiche tecniche e l'impostazione; si differenzia solo per la canna, realizzata in calibro .45, con sette righe e passo di rigatura di 1.200 mm, e per il peso, decisamente inferiore, che la rende bilanciata, e maneggevole.



WAADTLÄNDER

(1845 c.)

Mod. S.234 Standard
Mod. L.234 Deluxe

This version of the rifle, altogether similar to the Bristlen A Morges model of which it keeps the technical characteristics, differentiates itself for the barrel .45 caliber, twist 1:48 (1.200 mm), 7 grooves and the weight which is certainly lighter. It is a very well balanced, precise and handling rifle.

S.250

SWISS MATCH

(1750-1820 c.)

Mod. S.250

La tradizione svizzera delle carabine di precisione continua ancora oggi con un'arma molto attesa fra i tiratori abitualmente impegnati nella "Pennsylvania R", importante specialità protesa sempre di più ad acquisire ottimi risultati anche in termini di partecipazione. La canna, con profilo conico ottagonale, è brunita colore marrone, l'acciarino presenta una finitura tartarugata, e la bacchetta di caricamento è in acciaio. Lo scatto è servito da stecher a doppio grilletto e la tacca di mira, regolabile in verticale e orizzontale, può scorrere lungo la canna per la correzione della distanza oculare. Il calcio, in noce lucidato a olio, è completato da un calciolo avvolgente con il rampone superiore poco pronunciato.



SWISS MATCH

(1750-1820 c.)

Mod. S.250

The Swiss tradition of the target rifles continues today with a long awaited gun among the shooters usually attending the important "Pennsylvania R" discipline launched to acquire very good results and a larger participation. The barrel with an octagonal conical profile is rust brown finish colour, the lock is case hardened, the ramrod is in steel. The pull is served by a double set trigger, the rear sight, adjustable in elevation and windage, can slide along the barrel to correct the distance from the shooters eye. The walnut stock, oil finished, is completed with a steel hook butt plate, the upper part protruding only slightly.

Mod.	Cal.	Righe Grooves	Passo Twist mm - inches	Lungh. canna Barrel length mm - inches	Lungh. totale Overall length mm - inches	Peso Weight kg - lbs	Misura palla Ball/bullet size	Biocco pallottiere Bullet mould Our code
S./L.234	.45	7	1.200 - 1:48	782 - 30 ⁹ / ₁₆	1.230 - 48 ⁷ / ₁₆	6,900 - 15.20	.445 round	USA 307-445
S./L.235	.35	8	450 - 1:18	782 - 30 ⁹ / ₁₆	1.230 - 48 ⁷ / ₁₆	6,900 - 15.20	.347 long	USA 308-347
S./L.235	.44	4	660 - 1:26	782 - 30 ⁹ / ₁₆	1.230 - 48 ⁷ / ₁₆	7,700 - 16.97	.447 Minié	USA 304-447
S.250	.45	7	1.200 - 1:48	782 - 30 ⁹ / ₁₆	1.230 - 48 ⁷ / ₁₆	7,400 - 16.31	.454 round	USA 307-454

©





S.225



GIBBS

**Mod. S.225 Standard
Mod. L.225 Deluxe**

Riproduzione di uno dei più famosi fucili, nel campo del tiro di precisione, realizzato nel 1865 dall'inglese George Gibbs. Un'arma che nasce per accontentare sia i puristi dell'estetica sia i tiratori che desiderano cimentarsi nel tiro alla distanza di 100 metri e oltre. La canna, in acciaio brunita, presenta un profilo esterno a due ordini. Il calcio, in noce, è zigrinato e lucidato a olio ed è completato dalla cocchia e dal puntale anteriore in legno pregiato. L'impugnatura a pistola permette una posizione confortevole e un'ottima stabilità nel tiro.

È dotato di diottra di altissima precisione, regolabile in verticale e orizzontale con un'escursione verticale dell'oculare fino a 76 mm (3") ca. e di mirino a tunnel con bolla, regolabile in orizzontale per mezzo di una vite micrometrica, completato dal set di quindici inserti intercambiabili (USA 408). La versione Deluxe presenta incisioni finite a mano identiche a quelle presenti su un esemplare originale. L'acciarino, il tappo di culatta, la codetta e il paragrilletto mostrano un motivo sviluppato tramite una "inglesina" molto fine. Il calcio è realizzato in noce, selezionato, e l'impugnatura e l'astina presentano dei pannelli zigrinati.

GIBBS

**Mod. S.225 Standard
Mod. L.225 Deluxe**

Reproduction of one of the most famous rifles in the field of the precision target shooting, made in 1865 by the English gunsmith George Gibbs. A rifle born to satisfy both the aesthetical purists and the shooters who wish to challenge in the 100 meters target shooting and longer ranges. Blue, steel octagon to round barrel. The stock is made in walnut, checkered, oil finished and completed with a premium figured wood butt cap and nose cap. The pistol grip shape enables a comfortable grip and a very good

balance. Equipped with high precision Creedmoor sight, windage and elevation adjustment of the eye piece up to 3" about (76 mm), spirit level tunnel front sight with windage adjustable with a micrometer screw, completed with a set of 15 interchangeable inserts (USA 408). The Deluxe version is enriched with engravings finished by hand, identical to those shown on an original rifle. The lock, breech plug, tang and the trigger guard are engraved with a very fine "English" style pattern. The stock is made with selected walnut, the grip and the forend have a fine checkering.

Mod.	Cal.	Righe Grooves	Passo Twist		Lungh. canna Barrel length		Lungh. totale Overall length		Peso Weight		Misura palla Ball/bullet size	Blocco pallottiere Bullet mould Our code
			mm	- inches	mm	- inches	mm	- inches	kg	- lbs		
S./L.225	.40	6	406	- 1:16	835	- 32 ⁷ / ₈	1.250	- 49 ¹ / ₂	5,300	- 11.68	.400 Minié	USA 304-400
S./L.225	.45	6	450	- 1:18	915	- 36	1.330	- 52 ³ / ₈	5,300	- 11.68	.451 long	USA 308-451



2003 NRA RECORD, Camp Perry (USA):
Creedmoor Match: 800, 900 and 1000 Yards

2004 NRA RECORD, Quantico (USA):
Creedmoor Match: 800, 900 and 1000 Yards



WORLD CHAMPION

2005 World Long Range M.L. Championship,
Bisley (England): 300, 500, 600, 800 e 900 metri
(3 Gold - 2 Silver - 1 Bronze)

2007 World Long Range M.L. Championship,
Cape Town (Sudafrica): 300, 500, 600, 700, 800 e
900 metri (10 Gold - 9 Silver - 8 Bronze)



S.225

L.225

S.290

S.290



WORLD CHAMPION
Bordeaux (F) 2006

1857 WÜRTTEMBERGISCHEN

Mod. S. 290

Riproduzione fedele di una famosa arma d'ordinanza fabbricata dal 1857 al 1866 presso la Gewehrfabrik in Oberndorf. Si tratta del fucile da fanteria "Vereinsgewehr" (fucile federativo) modello 1857 adottato negli Stati del Württemberg, del Baden e del Granducato d'Assia.

(1857-1866)

Arma estremamente precisa, dotata di tacca di mira su alzo a quadrante con regolazione in verticale e orizzontale, è particolarmente adatto per il tiro di precisione a 100 metri nella specialità "Minié".

1857 WÜRTTEMBERGISCHEN

Mod. S.290

Faithful reproduction of a military rifle, which in the past Century it was manufactured by the Gewehrfabrik in Oberndorf from 1857 to 1866. The infantry Württembergisch "Vereinsgewehr" 1857 model, with percussion lock and rifled barrel 13,9 mm (.547) caliber, was adopted in the States of Württemberg, Baden and

(1857-1866)

Great Axia dukedom. An extremely accurate rifle reproduced to be a contender in the "Minié" 100 meters target shooting specialty. Equipped with a rear sight on a squared high base, adjustable for windage and elevation. It is a rifle which has to be carefully observed to appreciate the details, both technical and aesthetical ones.

Mod.	Cal.	Righe Grooves	Passo Twist		Lungh. canna Barrel length		Lungh. totale Overall length		Peso Weight	Misura palla Ball/bullet size	Blocco pallottiere Bullet mould Our code
			mm	- inches	mm	- inches	mm	- inches			
S.290	.54	5	1.400	- 1:55	1.000	- 39 ¹ / ₄	1.390	- 54 ¹ / ₄	4,600	- 10.14	.547 Minié USA 302-547

©





S.219

S.219 L.219

TRYON TARGET

(1845 c.)

Mod. S.219 Standard
Mod. L.219 Deluxe

Eccezionale riproduzione di fucile americano delle pianure, con stecher regolabile a due grilletti e acciarino a molla indietro. La canna ottagonale è brunita e le parti in acciaio color tartaruga. È dotato di tacca di mira regolabile in verticale e, a richiesta, può essere completato con diottra e mirino a tunnel.

Particolarmente apprezzato per la qualità esecutiva e la sua versatilità nel tiro di precisione e nella caccia è l'arma ideale anche per i neofiti.

Copia esatta dell'originale, il modello Deluxe, completamente inciso, è realizzato con canna color damasco e le parti in acciaio color argento vecchio. Il calcio è in noce, lucidato a olio.



TRYON TARGET

(1845 c.)

Mod. S.219 Standard
Mod. L.219 Deluxe

Exceptional reproduction of an American plains rifle, with double set trigger and back action. It is supplied with blued barrel and colour case hardened steel parts. Equipped with adjustable rear sight, it is tapped to accept a Creedmoor sight and tunnel front sight.

Particularly appreciated for the quality finishing and the versatility both for the target shooting and the hunting, it is the ideal rifle also for the neophites.

Exact copy of the original model, the Deluxe version shows rich engravings on lock and metal fittings. The steel fittings are coin colour finished; the stock is of walnut and the barrel is rust brown colour finish.



WORLD CHAMPION
Versailles (F) 1983

S.224

TRYON "MAPLE"

(1845 c.)

Mod. S.224

Splendida versione con calcio in acero, tipica essenza americana, appositamente importata per accontentare le richieste dei nostri collezionisti. La lucidatura viene eseguita a mano seguendo antiche tecniche dei Maestri artigiani del Nord America.



TRYON "MAPLE"

(1845 c.)

Mod. S.224

New version with maple stock, typical American style, expressly imported to satisfy the requirements of our collectors. The finishing is made following antique techniques of the North America master craftsmen.



S.229



WORLD CHAMPION

- Pforzheim (D) 1989 - "World record"
- Leusden (NL) 1990
- Camp Perry (USA) 1992 - "World record"
- Chur (CH) 1994
- Warwick (GB) 1996
- Warwick (GB) 1998 (Team)
- Batesville (USA) 2004

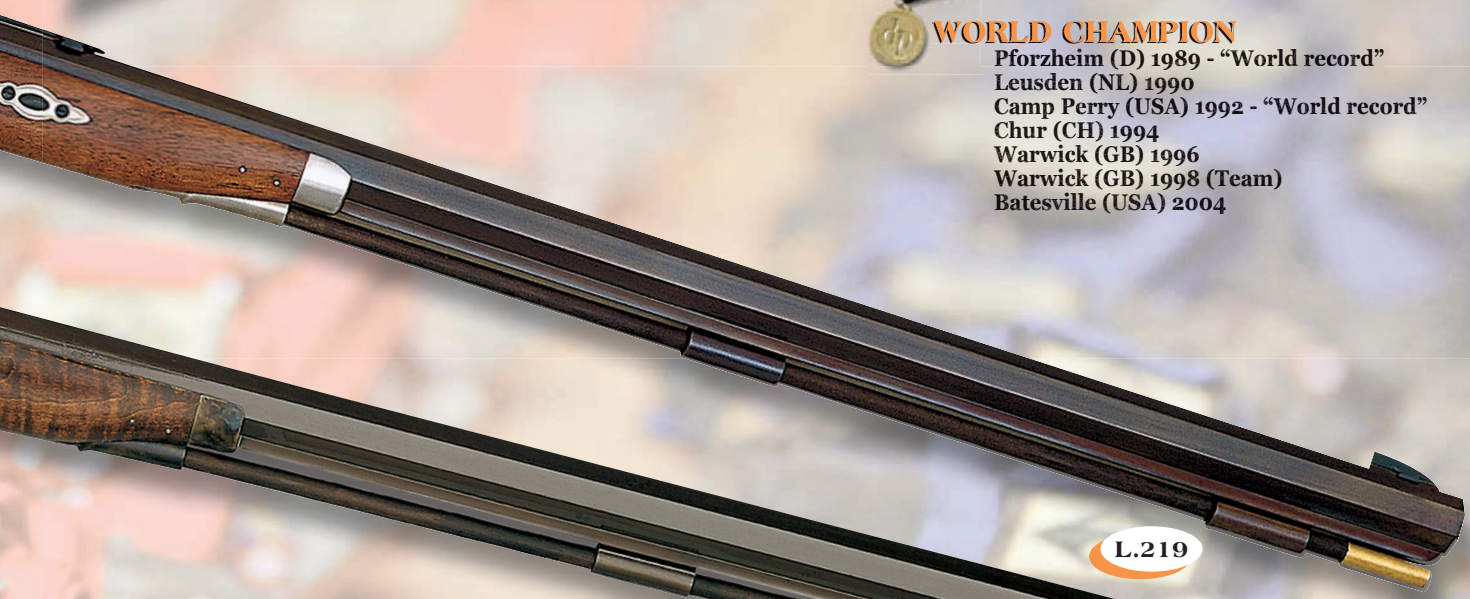

L.219

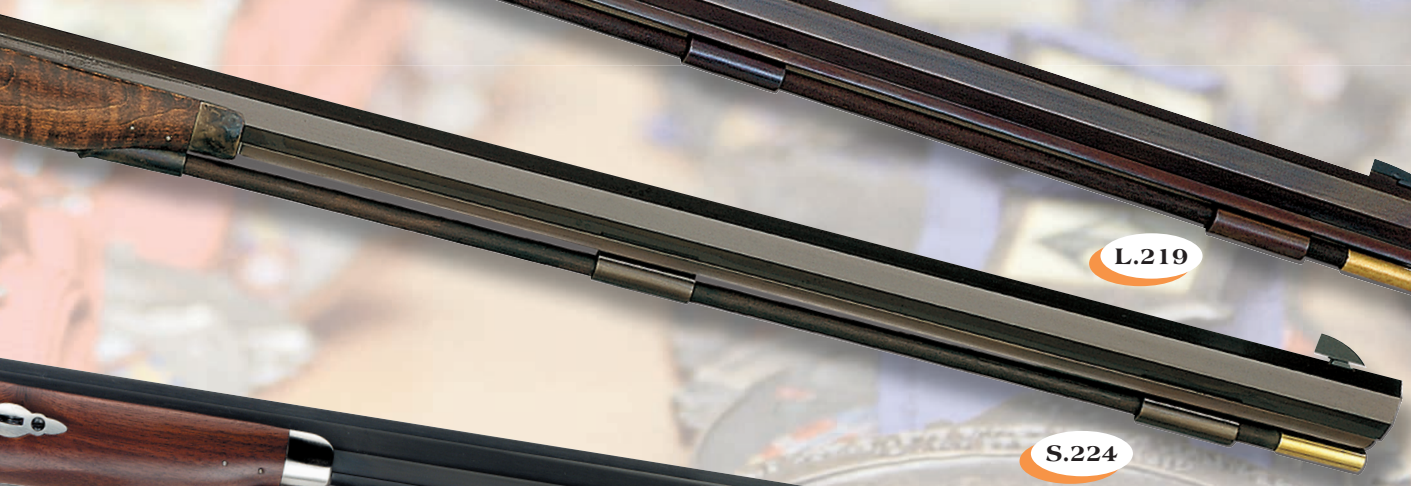

S.224



S.251

S.251

TRYON MATCH

(1845 c.)

Mod. S. 251

Le finiture color argento vecchio dell'acciarino, della tabacchiera e del puntale del calcio, e la canna con passo veloce che permette l'impiego di proiettili conici e Minié, contraddistinguono questa nuova versione del fucile Tryon. Dotato di diottra universale corta (USA 465) e mirino a tunnel completo di inserti intercambiabili (USA 469-A), questo fucile costituisce una ulteriore scelta per il tiro di precisione.



TRYON MATCH

(1845 c.)

Mod. S. 251

This new version of the Tryon rifle, equipped with Universal short Creedmoor sight (USA 465) and the front tunnel sight with interchangeable inserts (USA 469-A), is a further choice for the target shooting with its fast twist which allows the use of conical or Minié bullets. The barrel is blue and most of the garnitures are coin finish colour.

S.229

TRYON CREEDMOOR

(1845 c.)

Mod. S.229

Versione del fucile Tryon con canna brunita antiriflesso, ideale per il tiro di precisione a 100 metri. Il calcio in noce, finito a olio, è munito di portacinghia per garantire la stabilità di tiro. È dotato di diottra tipica dell'epoca, regolabile in orizzontale e di mirino a tunnel, con inserti intercambiabili. A richiesta è disponibile la diottra regolabile in verticale e orizzontale (USA 468).



TRYON CREEDMOOR

(1845 c.)

Mod. S.229

Version of Tryon rifle characterized by an anti reflective, blue finish barrel it is the ideal arm for 100 yards matches. The oil finished stock features a butt plate, particularly suited for 100 yards target shooting and two sling swivels. It is provided with a faithfully reproduced, typical Creedmoor sight adjustable for windage, and a tunnel front sight, with interchangeable inserts. On request it is available the Creedmoor sight adjustable for elevation and windage (USA 468).

Mod.	Cal.	Righe Grooves	Passo Twist		Lung. canna Barrel length		Lung. totale Overall length		Peso Weight		Misura palla Ball/bullet size	Blocco pallottiere Bullet mould Our code
			mm	- inches	mm	- inches	mm	- inches	kg	- lbs		
S./L219 · S.224	.45	6	1.200	- 1:48	820	- 32 ¹ / ₁₆	1.230	- 48 ¹ / ₁₆	4,400	- 9.70	.445 round	USA 307-445
S./L219 · S.224	.50	6	1.200	- 1:48	820	- 32 ¹ / ₁₆	1.230	- 48 ¹ / ₁₆	4,200	- 9.25	.490 round	USA 307-490
S./L219 · S.224	.54	7	1.660	- 1:65	820	- 32 ¹ / ₁₆	1.230	- 48 ¹ / ₁₆	4,200	- 9.25	.535 round	USA 307-535
S.229	.45	5	530	- 1:21	820	- 32 ¹ / ₁₆	1.230	- 48 ¹ / ₁₆	4,500	- 9.92	.451 long	USA 318-451
S.251	.45	5	530	- 1:21	820	- 32 ¹ / ₁₆	1.230	- 48 ¹ / ₁₆	4,600	- 10.14	.450 Minié	USA 309-450





S.240

S.278



MORTIMER

(1815-1830 c.)

Riproduzione di fucile inglese con canna a due ordini, ottagonale e tonda. Il calcio, in noce europeo con guanciaie di tipica foggia inglese, è lucidato a olio e zigrinato. L'acciarino e tutte le parti in metallo sono color tartaruga. Le versioni Deluxe, con acciarino e parti in metallo color argento vecchio, sono arricchite da incisioni con finiture eseguite a mano. La canna è impreziosita dalla scritta in oro "Mortimer".

MORTIMER

(1815-1830 c.)

Reproduction of an English rifle with octagonal to round barrel. The oil finished European walnut stock is completed by a typical English styled cheek piece and checkered. Colour case hardened lock and metal parts. The Deluxe version is enriched with engraving on the coin colour finished lock and fitting, and with the name "Mortimer" in gold letter on the barrel.

MORTIMER "WHITWORTH"

(1830 c.)

Mod. S.278 Standard
Mod. L.278 Lusso - A percussione

Ideale per il tiro di precisione a 100 metri, è dotato di mirino a tunnel, con inserti intercambiabili e di diottra regolabile in verticale e orizzontale. Prodotto con canna brunita è provvisto di portacinghia per garantire la stabilità di tiro.

MORTIMER "WHITWORTH"

(1830 c.)

Mod. S.278 Standard
Mod. L.278 Deluxe - Percussione

Ideal for 100 yards shooting, is provided with tunnel front sight with interchangeable inserts, and Creedmoor sight, adjustable for windage and elevation. Produced with blued barrel, is equipped with two sling swivels.



WORLD CHAMPION

Maximilian: Pforzheim (D) 1989 - "World record"
 Chur (CH) 1994 - "World record"
 Adelaide (AU) 2000
 Lucca (I) 2002
 Batesville (USA) 2004



L.278

L.239

S.278

S.239

S.240 L.240

MORTIMER (1815 c.)

Mod. S.240 Standard
 Mod. L.240 Deluxe - A pietra focaia

Prodotto con canna color damasco è dotato di portacinghia per garantire la stabilità di tiro. È il fucile ideale per il tiro di precisione a 50 e 100 metri.



MORTIMER (1815 c.)

Mod. S.240 Standard
 Mod. L.240 Deluxe - Flintlock model

Produced with rust brown finish colour rifled barrel. It is equipped with two sling swivels for a better shooting stability. It is the ideal for 50 and 100 yards shooting and hunting.

S.239 L.239

MORTIMER TARGET (1815 c.)

Mod. S.239 Standard
 Mod. L.239 Lusso - A pietra focaia

Con le stesse caratteristiche del modello S.240 è dotato di diottra regolabile in verticale e orizzontale e mirino a tunnel.



MORTIMER TARGET (1815 c.)

Mod. S.239 Standard
 Mod. L.239 Deluxe - Flintlock model

With the same characteristics of the S.240 model it is equipped with fully adjustable Creedmoor sight and tunnel front sight.

Mod.	Cal.	Righe Grooves	Passo Twist mm - inches	Lungh. canna Barrel length mm - inches	Lungh. totale Overall length mm - inches	Peso Weight kg - lbs	Misura palla Ball/bullet size	Blocco pallottiere Bullet mould Our code
S./L.239	.54	7	1.660 - 1:65	925 - 36 ¹ / ₁₆	1.325 - 52 ¹ / ₁₆	4,600 - 10.13	.535 round	USA 307-535
S./L.240	.54	7	1.660 - 1:65	925 - 36 ¹ / ₁₆	1.325 - 52 ¹ / ₁₆	4,600 - 10.13	.535 round	USA 307-535
S./L.278	.45	5	530 - 1:21	820 - 32 ¹ / ₁₆	1.225 - 48 ¹ / ₄	4,600 - 10.13	.451 long .450 Minié	USA 318-451 USA 309-450

©





S.283 S.295

ROCKY MOUNTAIN HAWKEN (1840-1865 c.)

S.283 - "Walnut" model
S.295 - "Maple" model

Arma simbolo del periodo che vide sia il passaggio dai lunghi e ingombranti *Pennsylvania rifles* ai più pratici e potenti *Plains rifles*, sia il definitivo abbandono della pietra focaia per il più moderno sistema a percussione. La robusta canna e il calibro quasi mai inferiore al .50 rivelarono subito una sorprendente precisione e quel fucile divenne compagno inseparabile dei solitari *Mountains men* e dei più famosi esploratori del continente americano. Il Rocky Mountain Hawken viene proposto con il calcio in acero oppure in noce e con canna solcata da sette righe ottenute per brocciatura e finita esternamente colore marrone; i fornimenti sono in acciaio.

ROCKY MOUNTAIN HAWKEN (1840-1865 c.)

S.283 - "Walnut" model
S.295 - "Maple" model

The Hawken is a symbol of the period that saw the passage from the long and heavy small caliber Pennsylvania rifles to more practical and powerful Plains rifles, and the definite abandoning of the flintlock for the far more modern percussion system. The strong barrel and the larger calibre, enabled hits on any target with surprising accuracy. This rifle soon became the inseparable friend of the Mountains men, and the most famous explorers of the American continent. The Rocky Mountain Hawken is offered with the maple stock or walnut stock with a barrel having 7 grooves obtained by broaching, rust brown colour finish, steel metal parts.

S.206 S.208

MISSOURI RIVER HAWKEN (1840-1865 c.)

Mod. S.206 - "Walnut" model
Mod. S.208 - "Maple" model

Il gradimento riscosso dal fucile Rocky Mountain Hawken e i suggerimenti di numerosi tiratori e cacciatori hanno contribuito alla definizione di questo modello rivisitato nel calibro, nel passo di rigatura e nella lunghezza della canna. Disponibile con la calciatura in acero oppure in noce. La canna presenta una sezione ottagonale con brunitura colore marrone, l'acciarino è color tartaruga. Lo scatto è servito da stecher a doppio grilletto. Ideale per la caccia e il tiro di precisione.

MISSOURI RIVER HAWKEN (1840-1865 c.)

Mod. S.206 - "Walnut" model
Mod. S.208 - "Maple" model

The popularity obtained by the Rocky Mountain Hawken rifle and the suggestions from several target shooters and hunters contributed to our adding new calibers, .45 and .50, twist and barrel length. Available with maple and walnut stock. The barrel features an octagonal cross-section, rust brown colour finish, and a case hardened colour lock. It is equipped with double set trigger. Perfect for hunting and target shooting.

Mod.	Cal.	Righe Grooves	Passo Twist mm - inches	Lungh. canna Barrel length mm - inches	Lungh. totale Overall length mm - inches	Peso Weight kg - lbs	Misura palla Ball/bullet size	Blocco pallottiere Our code
S.206 - S.208	.45	6	1.200 - 1:47	762 - 30	1.190 - 46 ¹ / ₈	4,200 - 9,26	.445 round	USA 307-445
S.206 - S.208	.50	6	600 - 1:24	762 - 30	1.190 - 46 ¹ / ₈	4,200 - 9,26	.500 long	USA 318-500
S.283 - S.295	.54	7	1.660 - 1:65	880 - 34 ¹ / ₈	1.300 - 51 ¹ / ₁₆	4,500 - 9,91	.535 round	USA 307-535





S.232 S.233

JÄGER HUNTER

(1750-1820 c.)

S.232 - A pietra focaia
S.233 - A percussione

Nato in Germania e nei Paesi limitrofi, soprattutto per la caccia, venne portato nel Nuovo Continente dagli emigranti in cerca di una nuova vita e di una nuova patria. Lo Jäger fu una delle armi più bilanciate e compatte, caratterizzato da un grosso calibro e dotato di stecher a due grilletti, era precisissimo e in grado di sparare palle con una energia molto elevata. Nato a pietra focaia, solo più tardi verrà trasformato in arma a percussione. La nostra produzione, oltre a riproporre le caratteristiche tecniche, garantendo ai tiratori ottimi risultati balistici grazie a rigature eseguite per brocciatura e parti meccaniche dell'acciaio prodotte con sofisticati macchinari a controllo numerico, racchiude in sé l'aspetto artistico riproponendo lo stesso tipo di tabacchiera con coperchio scorrevole, nonché il calcio in noce completato da fornimenti in acciaio. È l'arma ideale sia per la caccia sia per il tiro di precisione.

JÄGER HUNTER

(1750-1820 c.)

S.232 - Flintlock model
S.233 - Percussion model

The Jäger rifle is well known in Germany and in the neighbouring Countries especially for hunting, it was taken to the New Continent by immigrants looking for a new life in a new Country. The Jäger rifle was one the most balanced and compact rifles, very characteristic for its big calibre; equipped with double set trigger, it was very precise, able to shoot big balls having a very high energy. The Jäger rifle was first made in the flintlock version and only afterwards it was transformed to a percussion rifle. Our reproduction gives the shooter improved results due to the broached rifling as well as the lock parts produced on highly advanced computer controlled machines (CNC). The fine artistic beauty is captured in the patch box with sliding lid, in the walnut wood and completed with steel furniture and fittings which create a strong image for this rifle. It is a fine performing rifle, both for hunting and for target shooting.

S.246 S.249

JÄGER TARGET

(1750-1820 c.)

S.246 - A pietra focaia
S.249 - A percussione

Su richiesta di numerosi tiratori, il tradizionale fucile da caccia mitteleuropeo del Settecento assume un aspetto più sportivo e si veste di "giallo". Questa nuova versione infatti è caratterizzata dai fornimenti in ottone, dalla diottra regolabile in verticale e orizzontale e dal tipico mirino a tunnel aperto. Sulla canna è stata realizzata una brunitura antiriflesso color marrone e l'acciarino è color argento vecchio. Il calcio in noce, lucidato a olio, presenta due pannelli con zigrino a squame di pesce.



JÄGER TARGET

(1750-1820 c.)

S.246 - Flintlock model
S.249 - Percussion model

On request of many shooters, the traditional hunting rifle of the middle European 1700s period puts on a more sportive look, "dressing of yellow". This new version features brass furniture that remind those of the martial use, like the Creedmoor sight adjustable in windage and elevation and the typical open tunnel front sight. The barrel has a matt rust brown colour, the lock is coin finish colour. The walnut stock, oil finished, has a fine fish-like checkering of the grip.

Mod.	Cal.	Righe Grooves	Passo Twist mm - inches	Lungh. canna Barrel length mm - inches	Lungh. totale Overall length mm - inches	Peso Weight kg - lbs	Misura palla Ball/bullet size	Blocco pallottiere Our code
S.232 - S.233	.54	7	600 - 1:24	711 - 28	1.095 - 43 ¹ / ₈	3,700 - 8.15	.535 round	USA 307-535
S.246 - S.249	.54	7	1.660 - 1:65	820 - 32 ³ / ₈	1.205 - 47 ¹ / ₈	4,300 - 9.48	.540 maxi	USA 308-540
							.535 round	USA 307-535





S.265

S.266 S.267 S.268 L.269 S.269



FRONTIER

Mod. S.266 Standard - A pietra focaia
Mod. S.267 Standard - A percussione

FRONTIER "MAPLE"

Mod. S.268 Standard
Mod. L.268 Deluxe - A pietra focaia
Mod. S.269 Standard
Mod. L.269 Deluxe - A percussione

(1760-1840 c.)
Questa riproduzione di fucile americano, caratterizzato da calcio in acero o in noce, riproduce fedelmente gli esemplari originali in uso durante gli anni d'oro dei *Long Rifle* americani (1760-1840). Come i fucili di quell'epoca, famosi per la loro perfetta esecuzione, questo modello presenta una meticolosa lavorazione di tutti i particolari e un'accurata esecuzione di finitura. Il fucile è provvisto di stecher regolabile a due grilletti. Guardamano e calciolo sono in ottone; acciarino e guarniture sono color tartaruga e la canna è color damasco. I modelli con calcio in acero sono disponibili, nella versione Deluxe, con tabacchiera.

FRONTIER

Mod. S.266 Standard - Flintlock model
Mod. S.267 Standard - Percussion model

FRONTIER "MAPLE"

Mod. S.268 Standard
Mod. L.268 Deluxe - Flintlock model
Mod. S.269 Standard
Mod. L.269 Deluxe - Percussion model

(1760-1840 c.)

This replica, stocked in select American maple, or walnut, reproduces faithfully the original rifles produced during the golden age of the American long rifle (1760-1840). As with the squirrel rifles of this period, renowned for their accuracy at any range, this model reveals meticulous working of all metal parts and of the stock. The octagonal rifled barrel is rust brown colour finished. The rifle is provided with adjustable double set trigger. Trigger guard and butt plate are made of brass, lock and fittings are colour case hardened. The maple models are available in the Deluxe version, with patch-box.



S.266

S.264

L.269

S.269

S.267

S.264 S.265

FRONTIER CARBINE

Mod. S.264 - A pietra focaia
Mod. S.265 - A percussione

Leggera ed estremamente maneggevole, la versione carabina mantiene tutte le caratteristiche del fucile, salvo per le dimensioni e il peso. È prodotta con calcio in noce lucidato a olio e canna color damasco.

(1760-1840 c.)

FRONTIER CARBINE

Mod. S.264 - Flintlock model
Mod. S.265 - Percussion model

Very light and handy, the carbine version shows the same styling characteristics of the Frontier rifles, except for weight and dimensions. It is produced with walnut stock, oil finished and rust brown colour barrel.

(1760-1840 c.)

Mod.	Cal.	Righe Grooves	Passo Twist mm - inches	Lungh. canna Barrel length mm - inches	Lungh. totale Overall length mm - inches	Peso Weight kg - lbs	Misura palla Ball/bullet size	Blocco pallottiere Bullet mould Our code
S.264 - S.265	.50	6	860 - 1:34	710 - 28	1.105 - 43 1/2	2,900 - 6.39	.490 round	USA 307-490
S.264 - S.265	.54	7	860 - 1:34	710 - 28	1.105 - 43 1/2	2,800 - 6.17	.535 round	USA 307-535
S.266 - S.267	.32	7	1.200 - 1:48	990 - 39	1.390 - 54 1/2	3,600 - 7.93	.315 round	USA 307-315
S.266 - S.267	.36	7	1.200 - 1:48	990 - 39	1.390 - 54 1/2	3,400 - 7.49	.354 round	USA 307-354
S.266 - S.267	.45	8	1.200 - 1:48	990 - 39	1.390 - 54 1/2	3,200 - 7.05	.445 round	USA 307-445
S.266 - S.267	.50	8	1.200 - 1:48	990 - 39	1.390 - 54 1/2	3,500 - 7.71	.490 round	USA 307-490
S.266 - S.267	.54	8	1.660 - 1:65	990 - 39	1.390 - 54 1/2	3,400 - 7.49	.535 round	USA 307-535

© DP





S.210 S.213

KENTUCKY

(1750-1850 c.)

Mod. S.210 - A pietra focaia
Mod. S.213 - A percussione

Nato da un'elaborazione delle armi tedesche da caccia "Jäger", fu il grande rivale americano del fucile Brown Bess. Arma tipica dei coloni americani, il Kentucky divenne popolare negli Stati per la leggerezza e la precisione. La canna è brunita, i fornimenti sono in ottone e il calcio è in noce lucidato a olio.

KENTUCKY

(1750-1850 c.)

Mod. S.210 - Flintlock model
Mod. S.213 - Percussion model

This rifle evolved from the German hunting guns and was a major rival of the Brown Bess. Typical rifle in use in the American colonies it became, thanks to its lightness and accuracy, one of the most popular American rifles. The barrel is blue finished, all fittings are of polished brass and the walnut stock is oil finished.

S.214 S.217

ALAMO

(1750-1850 c.)

Mod. S.214 - A pietra focaia
Mod. S.217 - A percussione

Riproduzione del fucile usato dalle truppe texane durante la battaglia di Alamo, da cui il nome. Sulla tabacchiera sono riprodotte due scene della rivoluzione del Texas: "la resistenza di Alamo", difeso per tredici giorni da 189 militari contro 4.000 messicani, e "la resa del Generale Santa Ana", al Generale Sam Houston, dopo la battaglia di San Jacinto del 21 aprile 1836. È dotato di stecher regolabile a due grilletti e tacca di mira. La canna ottagonale è brunita e il calcio è in noce.



ALAMO

(1750-1850 c.)

Mod. S.214 - Flintlock model
Mod. S.217 - Percussion model

Reproduction of the historical rifle used by the Texas troops during the battle of the Alamo. Shown on the patch box are two scenes from the war of independence: the resistance of the Alamo, defended for 13 days by 189 soldiers against 4000 Mexicans and "General Santa Ana's" surrender to General Sam Houston, after the San Jacinto battle, on April 21st 1836. It is provided with adjustable double set trigger and rear sight. Blue finished barrel and walnut stock.

Mod.	Cal.	Righe Grooves	Passo Twist mm - inches	Lungh. canna Barrel length mm - inches	Lungh. totale Overall length mm - inches	Peso Weight kg - lbs	Misura palla Ball/bullet size	Blocco pallottiere Bullet mould Our code
S.210 - S.213	.32	7	1.200 - 1:48	903 - 35 ⁷ / ₁₆	1.275 - 50 ⁷ / ₁₆	3,500 - 7.71	.315 round	USA 307-315
S.210 - S.213	.45	8	1.200 - 1:48	903 - 35 ⁷ / ₁₆	1.275 - 50 ⁷ / ₁₆	3,200 - 7.05	.445 round	USA 307-445
S.210 - S.213	.50	8	1.200 - 1:48	903 - 35 ⁷ / ₁₆	1.275 - 50 ⁷ / ₁₆	3,700 - 8.15	.490 round	USA 307-490
S.214 - S.217	.32	7	1.200 - 1:48	915 - 36 ¹ / ₁₆	1.285 - 50 ³ / ₁₆	3,600 - 7.93	.315 round	USA 307-315
S.214 - S.217	.45	8	1.200 - 1:48	915 - 36 ¹ / ₁₆	1.285 - 50 ³ / ₁₆	3,300 - 7.27	.445 round	USA 307-445
S.214 - S.217	.50	8	1.200 - 1:48	915 - 36 ¹ / ₁₆	1.285 - 50 ³ / ₁₆	3,600 - 7.93	.490 round	USA 307-490
S.222 - S.223	.32	7	1.200 - 1:48	720 - 28 ³ / ₁₆	1.090 - 42 ³ / ₁₆	2,900 - 6.39	.315 round	USA 307-315
S.222 - S.223	.45	8	1.200 - 1:48	720 - 28 ³ / ₁₆	1.090 - 42 ³ / ₁₆	2,700 - 5.73	.445 round	USA 307-445
S.222 - S.223	.50	6	860 - 1:34	720 - 28 ³ / ₁₆	1.090 - 42 ³ / ₁₆	3,000 - 6.61	.490 round	USA 307-490
S.270 - S.275								
S.271 - S.276	.32	7	1.200 - 1:48	1.057 - 41 ³ / ₁₆	1.425 - 56 ¹ / ₁₆	3,800 - 8.37	.315 round	USA 307-315
S.270 - S.275								
S.271 - S.276	.45	8	1.200 - 1:48	1.057 - 41 ³ / ₁₆	1.425 - 56 ¹ / ₁₆	3,500 - 7.71	.445 round	USA 307-445



S.210

S.217

S.275

S.271

S.275 S.270

PENNSYLVANIA

(1750-1850 c.)

Mod. S.275 - A pietra focaia
Mod. S.270 - A percussione

È sicuramente una delle più belle riproduzioni di armi americane utilizzate dai cacciatori della Pennsylvania, da cui il nome. Fucile extra lungo, è prodotto con canna color damasco e calcio in noce, finito a olio.

È dotato di stecher regolabile a due grilletti e tacca di mira a rampa, regolabile in verticale.

S.223 S.222

SCOUT

(1750-1850 c.)

Mod. S.223 - A percussione
Mod. S.222 - A pietra focaia

Versione carabina del fucile Pennsylvania, utilizzato per la sua maneggevolezza, dagli scout che accompagnavano le carovane lungo le piste del West. È dotato di stecher regolabile a due grilletti e tacca di mira regolabile in verticale.



PENNSYLVANIA

(1750-1850 c.)

Mod. S.275 - Flintlock model
Mod. S.270 - Percussion model

Without a doubt one of the best reproduction of the American rifles used by Pennsylvania hunters, this extra long rifle, is finished with a rust brown colour barrel and the walnut completes the one piece oil finished stock. This model is provided with adjustable double set trigger. Front and rear sights are made of steel and rear sight is vertically adjustable.



SCOUT

(1750-1850 c.)

Mod. S.223 - Percussion model
Mod. S.222 - Flintlock model

Carbine version of the Pennsylvania rifle, thanks to its easy handling, it was mostly used by the famous Scout, that led the pioneers' caravans through the Western territories. It is provided with double set trigger, and ramp rear sight adjustable for elevation.

S.271 S.276

PENNSYLVANIA "DIXIE"

(1750-1850 c.)

Mod. S.271 - A percussione
Mod. S.276 - A pietra focaia

Modello di fucile Pennsylvania con tradizionale calcio in noce lucidato a olio. Questo fucile rientra nella categoria dei lavori ornamentali caratteristici della fine del 18° e dell'inizio del 19° secolo. È provvisto di stecher regolabile, a doppio grilletto e di tacca di mira a rampa regolabile in verticale.



PENNSYLVANIA "DIXIE"

(1750-1850 c.)

Mod. S.271 - Percussion model
Mod. S.276 - Flintlock model

Once again our company, always attuned the needs of the muzzle loading shooting public makes a full stocked traditional styled rifle. This gun falls into the category between the tool and the ornamental work of art of the late 18th and early 19th centuries. It is provided with double set trigger and ramp rear sight adjustable for elevation.



S.226 S.227

CUB "DIXIE"

(1750-1850 c.)

Mod. S.226 - A percussione
Mod. S.227 - A pietra focaia

Arma leggera e maneggevole, risulta particolarmente adatta anche per i giovani tiratori e per le signore. La canna, color damasco e il calcio in noce sono un perfetto completamento alla linea armoniosa di quest'arma. Tutte le parti ornamentali sono in ottone.

È munita di stecher regolabile e tacca di mira.



CUB "DIXIE"

(1750-1850 c.)

Mod. S.226 - Percussion model
Mod. S.227 - Flintlock model

Light and easy rifle to handle it is just right for young teenage shooters and for ladies. The rust brown finished colour barrel and the oiled walnut stock make a perfect complement to the graceful lines of this quality firearm. All fittings are made of brass. It is provided with adjustable double set trigger and rear sight.

S.236 S.237

COUNTRY HUNTER

(1780-1850 c.)

Mod. S.236 - A pietra focaia
Mod. S.237 - A percussione

Corto, maneggevole, semplice, era il fucile dei farmer americani.

Prodotto con canna ottagonale, brunita antiriflesso e acciarino tartaruga, questo fucile è l'ideale per coloro che vogliono avvicinarsi all'avancarica in modo economico per provare il piacere di questo nuovo sport. Trova applicazione soprattutto nell'attività venatoria.

COUNTRY HUNTER

(1780-1850 c.)

Mod. S.236 - Flintlock model
Mod. S.237 - Percussion model

This short, simple and manageable rifle was the favourite gun of the American farmers. Produced with "matt" finished barrel, it is the rifle for the new shooter of muzzle loading firearms, who wants an inexpensive way to start this pleasant sport. It's the ideal rifle for hunting.

Mod.	Cal.	Righe Grooves	Passo Twist mm - inches	Lungh. canna Barrel length mm - inches	Lungh. totale Overall length mm - inches	Peso Weight kg - lbs	Misura palla Ball/bullet size	Blocco pallottiere Bullet mould Our code
S.226 - S.227	.36	7	1.200 - 1:48	720 - 28 ³ / ₈	1.090 - 42 ⁵ / ₁₆	2,800 - 6.18	.354 round	USA 307-354
S.226 - S.227	.45	8	1.200 - 1:48	720 - 28 ³ / ₈	1.090 - 42 ⁵ / ₁₆	2,700 - 5.73	.445 round	USA 307-445
S.226 - S.227	.50	6	860 - 1:34	720 - 28 ³ / ₈	1.090 - 42 ⁵ / ₁₆	3,000 - 6.61	.490 round	USA 307-490
S.236 - S.237	.50	6	860 - 1:34	720 - 28 ³ / ₈	1.120 - 44 ¹ / ₈	2,700 - 5.73	.490 round	USA 307-490





S.282



K.282



S.226

S.236

S.282

INDIAN TRADE MUSKET

(1760-1830 c.)

Mod. S.282

Un modello che rispecchia fedelmente la tipologia dei fucili che, fino ai primi anni dell'Ottocento, venivano utilizzati dalle più note compagnie di commercio (Northwest Co., Hudson's Bay Co., American Fur Co.) per gli scambi con i nativi americani e i cacciatori bianchi. Questi fucili riproponevano le classiche linee dei moschetti della vecchia Europa e venivano prodotti sia da aziende europee sia dai più noti fabbricanti americani del tempo, come per esempio, Leman, Henry, Tryon e Deringer.

Il fregio a forma di serpente arricchito da incisioni, la bacchetta di caricamento in legno e il guardamano molto ampio erano caratteristiche tipiche di queste armi. Realizzato con calcio in noce e canna ad anima liscia colore damasco,

può essere impiegato nel tiro al piattello nella specialità Manton R, oppure nella caccia a caricamento sia a pallini sia a palla.

Nell'allestimento in kit sono comprese le borchie metalliche per creare dei fregi riferiti, per esempio, alla cultura dei Sioux Lakota. L'ornamento più frequente era quello di un cerchio con una croce all'interno per indicare la "Ruota di Medicina" o "Sacro Cerchio della Vita" (Cangleska Wakan). Esso rappresenta l'armonia dell'universo, con la forma circolare dei corpi e il loro movimento; la croce, invece, l'unione delle quattro direzioni che supportano la struttura del creato e la mantengono stabile. Il numero quattro può essere riferito anche alle stagioni, alle fasi della giornata, della esistenza dell'uomo, alle parti di una pianta, alle razze umane.

INDIAN TRADE MUSKET

(1760-1830 c.)

Mod. S.282

A model faithfully reflecting the type of rifles that since the late 1700s were used by the most well known trading companies (Northwest Co., Hudson's Bay Co., American Fur Co.) for the trades with the American Indians and the white hunters.

These guns showing the classical lines of the old European muskets produced both by European manufacturers and by the most well known American manufacturers, such as Leman, Henry, Tryon and Deringer.

The snake shape decoration is enriched by engravings. The wood ramrod and the large trigger guard were typical features of these guns. Made with walnut stock and rust brown colour

barrel can compete in the clay pigeon target class in the Manton R discipline, or it can be used for general hunting, loading either shot or a round ball. The kit version is supplied with metallic nails to create drawings referred, for instance to the Sioux Lakota's culture. The more frequent ornament was a circle with inside one cross to feature the "Medicine Wheel" or "The Sacre Life Circle" (Cangleska Wakan). It represents the harmony of the universe with the corps circular shape and their movement; the cross represents the unified four directions that support the creation structure, keeping it steady. The number four can refer to the Seasons, to the day's phases of the man's existence, the parts of a tree, or the human races.

Mod.	Cal.	Righe Grooves	Passo Twist mm - inches	Lungh. canna Barrel length mm - inches	Lungh. totale Overall length mm - inches	Peso Weight kg - lbs	Misura palla Ball/bullet size	Blocco pallottiere Bullet mould Our code
S.282	20	-	-	914 - 36	1.320 - 52	3,300 - 7.27	.614 round	USA 306-614





WORLD CHAMPION

- | | |
|-------------------|---|
| Hawker: | Camp Perry (USA) 1992
Warwick (GB) 1996
Adelaide (AU) 2000
Lucca (I) 2002
Batesville (USA) 2004 |
| Manton: | Camp Perry (USA) 1992
Adelaide (AU) 2000
Lucca (I) 2002
Batesville (USA) 2004 |
| Lorenzoni: | Batesville (USA) 2004
Bordeaux (F) 2006 "World Record" |



S.230 L.230

GIBBS SHOTGUN

**Mod. S.230 Standard
Mod. L.230 Deluxe**

La stessa eleganza del famoso fucile inglese di precisione si manifesta immutata anche in questa particolare versione leggera e maneggevole con canna a due ordini. L'acciarino è finito con il colore tartaruga; il calcio, con impugnatura a pistola, è realizzato in noce. La cocchia e il puntale dell'astina sono ingentiliti da inserti in legno pregiato. Un'arma ideale per il tiro al

piattello e per la caccia. Riproducendo le stesse incisioni create nella versione con canna rigata, la versione Deluxe si presenta con l'acciarino, il tappo di culatta, la codetta e il paragrilletto arricchiti da un motivo sviluppato tramite una "inglesina" molto fine. Il calcio, realizzato in noce selezionato, è completato dalle consuete zigrinature sull'impugnatura e sull'astina.

(1865)

GIBBS SHOTGUN

**Mod. S.230 Standard
Mod. L.230 Deluxe**

The same elegance of the famous English rifle is featured in this particular light and handy shotgun version, octagon to round barrel. The lock has a case hardened colour finish, the pistol grip stock is made of walnut. The grip cap and the forend cap have premium figured wood inserts. Perfect gun for clay pigeon target shooting and hunting.

Reproducing the same engravings of the rifle version, the Deluxe shotgun shows the lock, the breech plug, the tang and the trigger guard enriched with a very fine "English" scroll. The selected walnut stock, oil finished, is checkered at the grip and at the forend.



L.230

S.230

S.244

S.238

S.238 S.244



MORTIMER SHOTGUN

(1815-1830 c.)

- Mod. S.238 Standard
- Mod. L.238 Deluxe - A pietra focaia
- Mod. S.244 Standard
- Mod. L.244 Deluxe - A percussione

La tradizione di una delle più rinomate firme inglesi continua a vivere in questi fucili destinati alla caccia e al tiro al piattello, nelle cui specialità agonistiche possono vantare indiscussi primati già da lungo tempo. Il calcio è in noce lucidato a

olio e zigrinato nelle aree di presa dell'impugnatura e dell'astina. La canna, a due ordini, è brunita con un caldo color marrone nel modello a pietra focaia e con il colore nero in quello a percussione. Negli allestimenti Deluxe l'acciarino e altre parti metalliche presentano una finitura colore argento vecchio arricchita da eleganti incisioni con finiture eseguite a mano, mentre la canna è impreziosita con la scritta in oro "Mortimer".

MORTIMER SHOTGUN

(1815-1830 c.)

- Mod. S.238 Standard
- Mod. L.238 Deluxe - Flintlock model
- Mod. S.244 Standard
- Mod. L.244 Deluxe - Percussion model

The tradition of one of the most reckoned English gun makers signature continues to live in these shotguns designed for hunting and clay pigeon target shooting, in which disciplines they can claim ongoing medal winning for a long time. The oil finished walnut stock

is checkered at the grip and at the fore-end. The octagonal to round barrel is rust brown finish colour for the flintlock model while it is blued for the percussion model. In the Deluxe version the lock and the other metal parts are coin colour finish enriched with elegant engraving and with the name "Mortimer" in gold letter on the barrel.

Mod.	Cal.	Righe Grooves	Passo Twist mm - inches	Lungh. canna Barrel length mm - inches	Lungh. totale Overall length mm - inches	Peso Weight kg - lbs
S./L.230	12	-	-	820 - 32 ¹ / ₁₆	1.205 - 47 ¹ / ₁₆	3,900 - 8.59
S./L.238	12	-	-	925 - 36 ¹ / ₁₆	1.330 - 52 ¹ / ₁₆	3,800 - 8.37
S./L.244	12	-	-	820 - 32 ¹ / ₁₆	1.225 - 48 ¹ / ₁₆	3,500 - 7.71





L.247

L.241 S.285

DOPPIETTA CLASSIC

- Mod. L.241 cal. 12 - Standard
- Mod. LX.242 cal. 12 - Extra Deluxe
- Mod. S.285 cal. 20 - Standard
- Mod. LX.285 cal. 20 - Extra Deluxe

L.247

DOPPIETTA WATERFOWL

- (1850 c.)
- Mod. L.247 cal. 10 - Standard

(1850 c.)

Questa bella doppietta ad avancarica, riproduzione di un modello inglese, è da anni l'indispensabile compagna del cacciatore romantico. È prodotta con calcio in noce, canne, con leggera strozzatura, cromate internamente e brunite, e acciarini completamente incisi. I modelli Extra Deluxe sono arricchiti da incisioni con soggetti floreali e "inglesina" molto fine sugli acciarini, sulla codetta e sul paragrilletto. Il calcio in noce selezionato è zigrinato e le canne sono finite con brunitura color marrone.

SIDE BY SIDE SHOTGUN

"CLASSIC"

(1850 c.)

- Mod. L.241 12 Ga. - Standard
- Mod. LX.242 12 Ga. - Extra Deluxe
- Mod. S.285 20 Ga. - Standard
- Mod. LX.285 20 Ga. - Extra Deluxe

SIDE BY SIDE SHOTGUN

"WATERFOWL" (1850 c.)

- Mod. L.247 10 Ga. - Standard

This beautiful version of muzzle loading side by side shotgun, which reproduces an original English model has been the indispensable friend of the traditional hunter for many years. The stock is made of walnut, the blued barrels are slightly choked and inside chromed. The locks are engraved. The Extra Deluxe models are enriched with floral engravings and English scrolls on the lock, the tang and the trigger guard. The selected walnut stock is checkered and the barrels are rust brown colour finished.



LX.242-LX.285

L.241-S.285

S.293

DOPPIETTA SLUG

S.293
(1850 c.)

Mod. S.293

Per appassionati cacciatori, nasce questa nuova doppietta ad avancarica con calcio a pistola, acciarini e parti metalliche bruniti e bacchetta in fibra con puntale.

La canna, cromata internamente, con tacca di mira ribaltabile e mirino a perla, la rende ideale per la caccia sia a palla che a pallini in bosco.

SIDE BY SIDE SHOTGUN

"SLUG"
(1850 c.)

Mod. S.293

For those passionately fond of hunting, we made this muzzle loading side by side with pistol grip stock, blued locks and metal parts, fiberglass ramrod with jag. Cylinder barrels blued and chromed inside, with folding rear sight and pearl front sight. It is perfect for the hunting either with balls and shot.

VALIGETTA

USA 385

USA 385

Valigetta per doppietta avancarica. Misure (interne): 780x210 mm.

CASE

USA 385

Case for double barrel muzzle loading shotgun. Measures (inside): 30¹¹/₁₆"x8¹/₄" (780x210 mm)



Mod.	Cal.	Righe Grooves	Passo Twist mm - inches	Lungh. canna Barrel length mm - inches	Lungh. totale Overall length mm - inches	Peso Weight kg - lbs	Strozz. Chokes
L.241-LX.242	12	-	-	725 - 28 ¹ / ₁₆	1.125 - 44 ¹ / ₁₆	3,200 - 7.05	CYL / MOD.
L.247	10	-	-	762 - 30	1.170 - 46 ¹ / ₁₆	3,300 - 7.27	CYL / IMPR. CYL.
S./LX.285	20	-	-	700 - 27 ⁷ / ₁₆	1.110 - 43 ¹ / ₁₆	3,400 - 7.49	CYL / MOD.
S.293	12	-	-	650 - 25 ¹ / ₄	1.060 - 41 ¹ / ₄	3,200 - 7.05	CYL / CYL





L.245 L.248

KODIAK EXPRESS

(1850 c.)

**Mod. L.245
Kodiak Kombo
Mod. L.248**

Nel diciannovesimo secolo l'express ad avancarica fu l'arma utilizzata nelle battute di caccia nei vasti territori africani e indiani: con il nostro Kodiak, oggi, possiamo far sì che il sogno di tanti cacciatori continui a rimanere vivo.

La nostra arma è realizzata con canne rigate e bruniti, acciarini completamente incisi, tacca di mira regolabile e calcio in noce, con guanciaie e scudetto per le iniziali. Il Kodiak, utilizzato sempre con successo nelle battute di caccia negli Stati Uniti e in Africa, è considerato dai cacciatori ad avancarica il compagno ideale che permette di avere a disposizione un secondo colpo veloce e preciso.

È disponibile in diversi calibri e nella versione Kombo: con una canna rigata e una ad anima liscia calibro 12 e, a richiesta, con canne intercambiabili calibro 12.

KODIAK EXPRESS

(1850 c.)

**Mod. L.245
Kodiak Kombo
Mod. L.248**

In the 19th century the muzzle loading double barrel rifle was the gun for hunting in the wide African and India's regions. With our Kodiak today, we keep the dream alive for many hunters.

Our double express rifle has blued barrels, engraved locks, adjustable rear sight, walnut stock with cheek piece and a small German silver plate to complete with the initials. The Kodiak is used with success during the hunting sessions in Africa and in America and it is considered by the muzzle loading hunters the ideal rifle with its reliable and quick second shot.

It is available in various calibers and also in the Kombo version: one rifled barrel and one smooth barrel 12 gauge. On request it can be manufactured with interchangeable 12 gauge barrels.

L.245-72

SAFARI EXPRESS

(1850 c.)

Mod. L.245-72

Dopo circa un ventennio dalla sua introduzione, la gamma del Kodiak MK 3 viene arricchita dal modello "Safari Express" in calibro .72 con canne rinforzate per l'utilizzo di palle tonde da 500 grs. A richiesta può essere dotato di canne intercambiabili calibro 10.

USA 384

VALIGETTA

USA 384

Valigetta per doppietta ad avancarica con canne di ricambio.

Misure (interne): 800x290 mm.

SAFARI EXPRESS

(1850 c.)

Mod. L.245-72

After about twenty years from its introduction, the Kodiak MK3 is now completed in its range by "Safari Express" new model, .72 caliber, with alloyed steel barrels to shoot round balls weighting 500 grs. On request it can be equipped with interchangeable 10 gauge barrels.

CASE

USA 384

Case for double barrel muzzle loading shotgun and extra barrels.

Measures (inside): 31¹/₂"x11¹/₁₆" (800x290 mm)

Mod.	Cal.	Righe Grooves	Passo Twist		Lungh. canna Barrel length		Lungh. totale Overall length		Peso Weight		Misura palla Ball/bullet size	Blocco pallottiere Bullet mould Our code
			mm	- inches	mm	- inches	mm	- inches	kg	- lbs		
L245	.50	6	600	- 1:24	725	- 28 ¹ / ₁₆	1.135	- 44 ¹ / ₁₆	5,100	- 11.23	.490 round	USA 307-490
L245	.54	7	600	- 1:24	725	- 28 ¹ / ₁₆	1.135	- 44 ¹ / ₁₆	4,800	- 10.57	.535 round	USA 307-535
L245	.58	7	1.200	- 1:48	725	- 28 ¹ / ₁₆	1.135	- 44 ¹ / ₁₆	4,500	- 9.91	.575 round	USA 306-575
L245-72	.72	6	1.900	- 1:75	650	- 25 ¹ / ₁₆	1.090	- 42 ⁵ / ₁₆	4,700	- 12.55	.715 round	USA 306-715
L248	12x.54	6	600	- 1:24	725	- 28 ¹ / ₁₆	1.135	- 44 ¹ / ₁₆	4,800	- 10.57	/.490 round	USA 307-490
L248	12x.54	7	600	- 1:24	725	- 28 ¹ / ₁₆	1.135	- 44 ¹ / ₁₆	4,500	- 9.91	/.535 round	USA 307-535
L248	12x.58	7	1.200	- 1:48	725	- 28 ¹ / ₁₆	1.135	- 44 ¹ / ₁₆	4,200	- 9.25	/.575 round	USA 306-575



S.358-S.359

L.245

L.245-72

S.358 S.359

HOWDAH

(1840 c.)

**S.358 - Howdah Hunter
S.359 - Howdah Hunter "Kombo"**

Classica pistola a canne giustapposte che ripropone lo stile delle armi di scuola anglosassone utilizzate nella seconda metà dell'Ottocento per la caccia nei lontani territori coloniali. Durante il primo periodo del governo colonialista britannico in India le pistole howdah, per la loro potenza e affidabilità, erano le preferite dagli ufficiali dell'esercito inglese distaccati negli sconfinati avamposti dell'Impero, ma il principale impiego era nella caccia alle prede selvatiche o particolarmente pericolose.

Il termine howdah si riferisce alla portantina, o piattaforma, installata sul dorso dell'elefante.

Gli acciarini sono abbelliti da incisioni con soggetti di animali selvatici immersi nel loro habitat naturale, e finiti color tartaruga. Il calcio, in noce, presenta una impugnatura su cui sono stati realizzati due pannelli zigrinati per consentire una presa salda, confortevole ed equilibrata grazie anche alla coccia che funge da contrappeso.

In sintonia con la consolidata tradizione inglese, l'arma può essere completata da un cofanetto in legno corredato da accessori.

HOWDAH

(1840 c.)

**S.358 - Howdah Hunter
S.359 - Howdah Hunter "Kombo"**

Classic pistol with side by side barrels reproducing the Anglo-Saxon guns' style used for the hunt in the second half of the Eighteen hundreds in the far colonial territories and India.

During the first period of the British colonial government in India, the Howdah pistols for their power and reliability were preferred by the officers of the English army in the far away outposts of the wide empire, but the main use was at close range to stop dangerous wild animals such as the tiger which were known to leap upon

the Howdah atop the elephants back. The Howdah name is the palanquin mounted on the elephant. The locks are embellished with engraving featuring wild animals in their natural habitat, case hardened colour finish. The walnut stock has two checkered sections to grant a firm, comfortable and stable grip, thanks to the counterweight butt plate. Similar with cased guns of the English tradition, the gun is also offered in a mahogany case with accessories.

Mod.	Cal.	Righe Grooves	Passo Twist mm - inches	Lungh. canna Barrel length mm - inches	Lungh. totale Overall length mm - inches	Peso Weight kg - lbs	Misura palla Ball/bullet size	Blocco pallottiere Bullet mould Our code
S.358-20	20	-	-	285 - 11 ¹ / ₄	450 - 17 ³ / ₄	2,000 - 4.40	-	-
S.358-50	.50	12	450 - 1:18	285 - 11 ¹ / ₄	450 - 17 ³ / ₄	2,300 - 5.07	.490 round	USA 307-490
S.359	20x.50	12	450 - 1:18	285 - 11 ¹ / ₄	450 - 17 ³ / ₄	2,100 - 4.63	-/.490 round	USA 307-490





S.292

S.255



**1763 LÉGER (1766)
CHARLEVILLE (1766-1769)
Mod. S.255**

Nel 1763 la Francia aveva adottato un nuovo fucile da fanteria, più robusto dei precedenti, per rispondere alle esigenze di fuoco accelerato poste dalle tattiche affermatesi durante la guerra dei Sette Anni. Il nuovo fucile, troppo pesante, fu sostituito dopo tre anni dal modello 1766, progettato da M. de Montbeillard, ispettore della Manifattura di Saint-Etienne e fabbricato in più di 150.000 esemplari fino al 1769. Dopo tale anno fu progressivamente sostituito dal modello 1770/71, e le armi restituite dai reparti furono poi impiegate nel 1775 allo scoppio della Guerra d'Indipendenza Americana, quando la Francia distribuì numerosi fucili modello 1766 alle truppe dei nascenti Stati Uniti d'America.

**1763 LÉGER (1766)
CHARLEVILLE (1766-1769)
Mod. S.255**

In 1763 France adopted a new infantry musket, more strong than the previous one, to answer the needs of an accelerated fire coming from the war tactics developed during the Seven Years War. The new gun was found too heavy and was replaced after only three years by the 1766 Model, promoted by M. de Montbeillard, inspector of the Manufacturer of Saint-Etienne, built in more of 150,000 units until 1769. After this date it has been replaced by the Model 1770/71 and the muskets given back from the soldiers have been used in 1775 when the American Independence War started and France distributed numerous 1766 muskets to the troops of the new born United States of America.

S.256



**1777 REVOLUTIONNAIRE
Mod. S.256**

Arma rappresentativa della fanteria durante la Rivoluzione Francese, è il risultato delle modifiche che furono apportate ai vari fucili prodotti dal 1765, come l'intercambiabilità di tutti i pezzi fra un'arma e l'altra. Le caratteristiche peculiari di questo modello evidenziano la fascetta intermedia e il bocchino trattenuti per mezzo di viti e il profilo angolato della martellina. Tutte le parti metalliche sono in acciaio tranne lo scodellino che è in ottone; il calcio in noce, è lucidato a olio.

**1777 REVOLUTIONNAIRE
Mod. S.256**

Representing the infantry gun during the French Revolution, it is the result of the modifications made to various muskets produced since 1765, with all the interchangeable parts from one gun to the other. The peculiar features of this musket put into evidence the middle band and the front band fixed with screws and the angular frizzen profile. All the metal parts are made of steel, except the pan made of brass; the walnut stock is oil finish.



WORLD CHAMPION
Pforzheim 1989 (D)
Leusden 1990 (NL)
Warwick (GB) 1996

S.258

1777 CORRIGÉ "AN IX"
(1801-1820)

Mod. S.258

Riproduzione fedele del famoso fucile francese a pietra focaia modificato e adottato nel 9° anno della Rivoluzione Francese. Arma base delle fanterie napoleoniche, è del tutto simile al suo predecessore, modello 1777: si differenzia solo per la forma della martellina e per le molle di tenuta delle fascette. Tutte le parti metalliche sono in acciaio tranne lo scodellino che è in ottone; il calcio in noce, è lucidato a olio.

MLAIC

1777 CORRIGÉ "AN IX"
(1801-1820)

Mod. S.258

Faithful reproduction of the famous French flintlock musket, modified and adopted on the 9th year of the French Revolution. Basic gun for the Napoleon army, it is quite similar to its predecessor the 1777 Model, the differences are in the frizzen shape and in the bands' springs. All the metal parts are made of steel, except for the pan that is made of brass; the walnut stock is oil finish.

S.255

S.258

S.256

MLAIC

S.292

"AN IX" DRAGOONS
(1801-1819)

Mod. S.292

I Dragoni, nati nel Seicento come speciale corpo di Fanteria che si spostava a cavallo per poi combattere a piedi, divennero alla fine del Settecento una specialità della Cavalleria e quindi dotati di carabine. Erano armi molto simili, per modello e calibro a quelli della Fanteria ma un po' più corti e leggeri: avevano fornimenti in ottone per evitare l'ossidazione dovuta al sudore del cavallo e la granatiera in ferro a doppia banda per sopportare lo sforzo di trazione della bretella quando l'arma veniva portata a tracolla andando al trotto. La nostra riproduzione riprende tutte le caratteristiche dell'arma originale ed è prodotta con calcio in noce.

"AN IX" DRAGOONS
(1801-1819)

Mod. S.292

The Dragoons, special Infantry corps in the 1600s that rode horses, but fought like the Infantry corps, and by the end of the 1700s they had become a regular cavalry force equipped with carbines. They were very similar, for model and caliber to the infantry muskets, but lighter and shorter, with brass furniture to avoid oxidation due to horse's sweat, the double iron bands to stand the traction of the belt when the gun was shouldered trot riding a horse. Our reproduction copies all the original features of the musket. The stock is made of walnut.

S.205



D.820-D.640

Mod.	Cal.	Righe Grooves	Passo Twist mm - inches	Lungh. canna Barrel length mm - inches	Lungh. totale Overall length mm - inches	Peso Weight kg - lbs	Misura palla Ball/bullet size	Blocco pallottiere Our bullet mould Our code
S.255	69 (17,5 mm)	-	-	1.135 - 44 ¹ / ₁₆	1.520 - 59 ¹ / ₈	4,600 - 10.13	.675 round	USA 306-675
S.256	17,5 mm (.69)	-	-	1.135 - 44 ¹ / ₁₆	1.510 - 59 ¹ / ₁₆	4,500 - 9.92	.675 round	USA 306-675
S.258	17,5 mm (.69)	-	-	1.135 - 44 ¹ / ₁₆	1.510 - 59 ¹ / ₁₆	4,500 - 9.92	.675 round	USA 306-675
S.292	17,5 mm (.69)	-	-	1.025 - 40 ⁷ / ₁₆	1.415 - 55 ¹ / ₄	4,400 - 9.69	.675 round	USA 306-675





S.263

1798 AUSTRIAN

(1798-1829)

Mod. S.263

Nel 1792 l'Austria si trovò coinvolta nelle Guerre della Rivoluzione e dell'Impero; il Ministero della Guerra di Vienna dovette fronteggiare il nuovo modo di combattere delle armate della Rivoluzione basato sulla velocità di spostamento e su nuove tattiche di fanteria. Si pensava che parte del merito delle vittorie dei francesi fosse da attribuire al loro nuovo fucile modello 1777 e così, alla fine della Prima Campagna d'Italia, fu costituita una Commissione incaricata di adottare nuove armi per l'esercito austriaco. Il 26 luglio 1798 nasce il nuovo modello che, pur ispirato a quello francese, presenta altre caratteristiche tipicamente austriache, come il voluminoso bocchino, la bacchetta con calcatoio di nuovo profilo e la lunga baionetta a quattro fili. Il fucile mod. 1798 è un'arma ben costruita, molto robusta e per alcuni versi superiore al suo progenitore francese. Il calcio è in noce e le parti metalliche in acciaio, eccezion fatta per le fascette, il guardamano e lo scodellino che sono in ottone.



1798 AUSTRIAN

(1798-1829)

Mod. S.263

On 1792 Austria was involved in the Wars of Revolution and of the Empire; the War Ministry in Vienna had to face a new way to fight the Revolution corps, based on the need to quickly move the troops and on new infantry tactics. The belief was that the reason for the French victories was due to their Model 1777 musket, so at the end of the First Italian Campaign, a commission was charged to adopt new guns for the Austrian army. On the 26th of July 1798 came the new model, that even if inspired by the French model, has other typical Austrian features, like the voluminous front band, the ramrod with a new profile and the long bayonet with four edges. The musket Model 1798 is a well made gun, very strong and for some points it is better than its French progenitor. The stock is made of walnut, steel metal furniture, except the bands, the trigger guard and the pan that are made of brass.

S.261

1809 PRUSSIAN

(1809-1830)

Mod. S.261

Trae le sue origini dal noto 1777 con alcune varianti del tutto teutoniche. Originariamente prodotto in Potsdam, la nostra riproduzione ripresenta tutte le caratteristiche dell'originale. La canna è satinata e l'acciarino, che ricorda il 1777, è marcato Potsdam; le altre parti sono in ottone. Il calcio è in noce lucidato a olio.



1809 PRUSSIAN

(1809-1830)

Mod. S.261

Takes its origins from the famous 1777 musket, differing from this only in some minor details. This musket faithfully reproduces the original model made in Potsdam. The barrel is of polished steel and all metal parts are of brass. The walnut stock is oil finished. The polished steel lock, recalls the 1777 model, and is inscribed "Potsdam".

Mod.	Cal.	Righe Grooves	Passo Twist mm - inches	Lungh. canna Barrel length mm - inches	Lungh. totale Overall length mm - inches	Peso Weight kg - lbs	Misura palla Ball/bullet size	Blocco pallottiere Bullet mould Our code
S.202	17,5 mm (.69)	-	-	760 - 29 ⁹ / ₁₆	1.140 - 44 ¹ / ₁₆	3.300 - 7.27	.675 round	USA 306-675
S.204	17,5 mm (.69)	-	-	704 - 27 ⁷ / ₁₆	1.065 - 41 ⁹ / ₁₆	3.200 - 7.05	.675 round	USA 306-675
S.261	19,05 mm (.75)	-	-	1.045 - 41 ¹ / ₁₆	1.435 - 56 ¹ / ₁₆	4.000 - 8.81	.732 round	USA 306-732
S.263	17,5 mm (.69)	-	-	1.135 - 44 ¹ / ₁₆	1.510 - 59 ¹ / ₁₆	4.700 - 10.36	.675 round	USA 306-675





S.261



S.204

S.263



S.202

S.204

USSARO MOD. 1786

(1786-1815)

Mod. S.204

Gli ussari, reparti della cavalleria leggera, erano incaricati di scortare i convogli, esplorare le linee nemiche, porsi come avanguardia o copertura dei reggimenti. L'arma da spalla creata per tali reparti, leggera e di facile impiego, nasce nel 1767 nell'arsenale di Charleville. Dopo l'adozione del sistema 1777 si studiano nuove varianti e nel 1786 si giunge al modello definitivo, prodotto negli arsenali di Saint-Etienne, Charleville e, fino al 1815, in quello di Maubeuge.

L'acciarino, marcato con il riferimento dell'arsenale di Saint-Etienne, è quello del tradizionale sistema An IX oramai in uso dai primi anni del 1800, ma con dimensioni intermedie rispetto a quelle della pistola da cavalleria e del moschetto da fanteria.

Questo moschetto ripropone una delle più famose fra le armi utilizzate nelle campagne napoleoniche e una delle più ambite fra i collezionisti; può essere impiegato nelle rievocazioni storiche e, per la sua maneggevolezza, anche nel tiro a segno sportivo.



USSARO MOD. 1786

(1786-1815)

Mod. S.204

Known also as Light Cavalry Musket, it reproduces one of the French most famous musket, long for the collectors. The lock has the Saint Etienne Arsenal marks and is made on the traditional An IX system, but with smaller dimension compared to those of the pistol and the infantry musket. Can be employed in the re-enactment events and, for its easy handling, to be used for the target shooting.

S.202

AN IX DE CAVALLERIE

(1800-1816)

Mod. S.202

Riproduzione di uno dei modelli più rappresentativi nell'armamento delle truppe napoleoniche. Venne assegnato a tutta la cavalleria (cacciatori, cavalleggeri, granatieri, lancieri, carabinieri e corazzieri), compresi gli ussari che, però, preferirono sempre il loro moschetto Modello 1786, più leggero e più corto. Con l'apporto di piccole modifiche, l'arma fu distribuita anche ad alcuni corpi di fanteria e alla marina. Il moschetto da cavalleria venne fabbricato fino al 1816 in circa 225.000 esemplari e, tanti altri Stati europei, lo imitarono per armare i propri reparti come, per esempio, dal 1814, i Reali Carabinieri a Cavallo del Regno di Sardegna.

Realizzato con canna ad anima liscia e calcio in noce lucidato a olio, presenta alcuni fornimenti in ottone quali il calciolo, il paragrilletto, il fregio e il bocchino.



AN IX DE CAVALLERIE

(1800-1816)

Mod. S.202

Reproduction of one of the most representative models equipping the Napoleon troops. It equipped all the cavalry corps (hunters, cavalrymen, grenadiers, lancers, carabineers and dragoons) including the hussars, who however always preferred their 1786 musket, lighter and shorter. With small modification the gun was distributed to some infantry corps and to the navy. The cavalry musket was manufactured until the 1816 in about 225,000 units and several other European countries imitated it to equip their corps, like for instance the Royal Cavalry Carabineers of the Sardinia Reign, 1814.

Produced with smooth barrel and oil finished walnut stock, some of the metal furnitures are in brass, like the butt plate, the trigger guard, the side plate and the front band.



S.260

BROWN BESS

(1715-1835)

Mod. S.260

Il Brown Bess fu l'arma impiegata dai soldati inglesi durante l'estensione e il consolidamento dell'impero in India e in America. Veterano della guerra dei Sette Anni, fu utilizzato dagli uomini di Wellington nella guerra della penisola Iberica e a Waterloo. Le fanterie di quasi tutto il mondo lo imbracciarono, dalle nazioni europee alleate degli inglesi alle truppe messicane, che lo utilizzarono fino all'ultima battaglia della guerra con gli Stati Uniti (Chapultepec, 13 settembre 1847).

Sull'acciarino della nostra replica sono indicate sia la firma dell'armaiolo William Grice (e la data 1762) sia le cifre reali, con la corona e le lettere GR (Georgius Rex). La canna, ad anima liscia è in acciaio satinato e il calcio è in noce lucidato a olio. A richiesta sono disponibili la baionetta e il suo fodero.



BROWN BESS

(1715-1835)

Mod. S.260

The Brown Bess was the musket used by the English troops during the Empire extension and consolidation in India and America. Veteran of the Seven Years War, it was used also by Wellington during the war in the Iberian Peninsula and at Waterloo. The infantry troops of almost the entire world used it, from the European Nations allied with the English to the Mexican troops, who used it until the last battle with United States on the 13th of September 1847 at Chapultepec. Our reproduction has a lock with the signature of the gunsmith William Grice and the date 1762, the crown and the alphabetical letters GR (Georgius Rex). The smooth bore barrel is made of steel, satin finish, the walnut stock is oil finish. Available are the bayonet and the scabbard.

S.262

BROWN BESS CARBINE

(1715-1835)

Mod. S.262

Tra il 1756 e il 1813 il "Board of Ordnance" inglese dispone la realizzazione di alcune versioni più corte del fucile regolamentare da Fanteria. Con lunghezze di canna che variavano da 26 a 37 pollici, tali armi erano destinate ai Dragoni, ai Granatieri, alla Reale Guardia a cavallo, all'Artiglieria e ad alcuni corpi di volontari. La nostra replica della carabina si ispira a questa serie di modelli e mantiene le stesse caratteristiche del fucile Brown Bess, come il calcio in noce e la canna color argento vecchio.



BROWN BESS CARBINE

(1715-1835)

Mod. S.262

Between 1756 and 1813 the English "Board of Ordnance" required the production of shorter versions of the regular infantry musket. The barrel's lengths varied from 26" to 37", equipping the corps of the Dragoons, the Grenadiers, the Royal Horse-Guards and the Artillery, as well as some volunteers corps. Our reproduced carbine is inspired by this series and keeps the same features of the Brown Bess, like the walnut stock oil finish and the satin finish of the barrel.

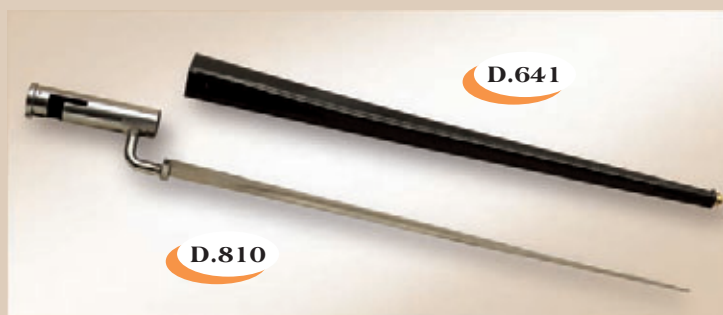

D.641

D.810



S.262



WORLD CHAMPION
 Versailles (F) 1983
 Toronto (Canada) 1987
 Warwick (GB) 1998
 Batesville (USA) 2004
 Bordeaux (F) 2006



S.260



S.298



S.274

S.298

1795 SPRINGFIELD
 (1795-1814)

Mod. S.298

Ispirata al moschetto Charleville Mod. 1763, fu la prima arma militare prodotta nell'arsenale di Springfield, nel Massachusetts. Il segretario del Ministero della Guerra Timothy Pickering suggerì l'arma francese come punto di partenza in modo da potere utilizzare alcuni componenti giacenti nei magazzini di Springfield, operativi fino al 1794 sia come depositi sia come officine per le riparazioni. Il Modello 1795 fu prodotto fino al 1814 in circa 85.000 esemplari. La nostra arma ripropone fedelmente un esemplare fabbricato tra il 1799 e il 1802; tutti i fornimenti sono in acciaio e il calcio è in noce.



1795 SPRINGFIELD
 (1795-1814)

Mod. S.298

Inspired by the Charleville Mod.1763 musket, it was the first military gun produced in the arsenal of Springfield, Massachusetts. The War Ministry secretary, Timothy Pickering, suggested the French musket to start production with, such to use some of the parts stocked in the Springfield's warehouses since 1794 assigned as deposits and gunsmithing for the guns repairs. The Model 1795 was produced in about 85,000 units until 1814. Our reproduction faithfully copy an original manufactured between 1799 and 1802; all the furniture are made of steel and the stock is made of walnut.

S.274

1816 HARPER'S FERRY
 (1816-1844)

Mod. S.274

Il fucile U.S. Mod. 1816, fabbricato negli arsenali di Harper's Ferry e Springfield tra il 1816 e il 1844, era ispirato al modello 1777 francese. Prodotto in notevoli quantità e, più tardi, trasformato a percussione, fu utilizzato anche durante la Guerra Civile. La canna, in acciaio, è trattenuta da tre fascette e tutte le parti metalliche sono satiniate. Il calcio, in noce lucidato a olio, riporta il marchio JP dei controllori governativi.



1816 HARPER'S FERRY
 (1816-1844)

Mod. S.274

The U.S 1816 musket was originally produced in the arsenals at Harper's Ferry and Springfield between 1816 and 1844, taking the design from the famous 1777 French muskets. It was first produced in large quantities, in the flintlock version and later converted to percussion, to be used during the Civil War. The barrel is made of polished steel and fastened to the stock by two bands. The walnut stock is oil finished and shows the government "J.P." proof mark.

Mod.	Cal.	Righe Grooves	Passo Twist mm - inches	Lungh. canna Barrel length mm - inches	Lungh. totale Overall length mm - inches	Peso Weight kg - lbs	Misura palla Ball/bullet size	Blocco pallottiere Bullet mould Our code
S.260	.75	-	-	1.060 - 41 ¹ / ₄	1.465 - 57 ¹ / ₁₆	4,100 - 9.03	.732 round	USA 306-732
S.262	.75	-	-	775 - 30 ¹ / ₂	1.200 - 47 ¹ / ₄	3,600 - 7.93	.732 round	USA 306-732
S.274	.69 (17,5 mm)	-	-	1.060 - 41 ¹ / ₄	1.450 - 57 ¹ / ₁₆	4,400 - 9.70	.675 round	USA 306-675
S.298	.69 (17,5 mm)	-	-	1.135 - 44 ¹ / ₁₆	1.525 - 60	4,600 - 10.13	.675 round	USA 306-675





S.273

**1816 HARPER'S FERRY
COLT CONVERSION
(1855-1858)**

Mod. S.273

Tra il 1848 e il 1860 negli arsenali di Springfield e di Harper's Ferry circa 700.000 fucili Modello 1816 furono trasformati a percussione.

La nostra replica riproduce la conversione secondo il sistema che Samuel Colt realizzò, dal 1855 al 1858, su diverse migliaia di fucili acquistati presso i depositi di New York. L'ingegnoso costruttore utilizzò lo stesso foro del focone per avvitare un portaluminello dotato anche di vite trasversale di ispezione e pulizia, e sostituì il cane con uno dal disegno inconfondibile. Una fornitura di 23.500 di questi fucili, ma con la canna rigata, giunse a Messina nell'agosto 1860 per armare i Mille di Garibaldi durante la famosa spedizione, ma sembra che solo la metà sia stata distribuita.

Nel nostro Mod. 1816 i fornimenti sono in acciaio satinato e l'acciarino è marcato HARPER'S FERRY 1816 con l'aquila americana e le lettere U.S.

MLAIC

**1816 HARPER'S FERRY
COLT CONVERSION
(1855-1858)**

Mod. S.273

Between 1848 and 1860 in the Springfield and Harper's Ferry's arsenals about 700,000 Model 1816 muskets were converted to percussion lock type. Our replica reproduces the conversion according to the system Samuel Colt made from 1855 to 1858 on many thousands of the muskets purchased from the US Army stockpile held in New York. The Colt conversion used the original touch hole to screw in the drum (equipped with a transverse plug screw for cleaning) and replaced the hammer with one of unique design. A quantity of about 23,500 of these muskets, with rifled barrels, was shipped to Messina in August 1860 to be distributed to the "1000 followers of Garibaldi" during the famous "1000's expedition", but probably only half had been distributed. Our Model 1816 has satin steel furniture, the lock is marked with HARPER'S FERRY 1816, the American Eagle and U.S. letters.

S.243

**1861 SPRINGFIELD
(1861-1865)**

Mod. S.243

Originalmente prodotto nel 1861, in quantità limitata nell'arsenale di Springfield, costituisce uno dei modelli storici più importanti dell'epoca. Più efficiente dei suoi predecessori ad anima liscia, fu protagonista nella Guerra di Secessione. Prodotto con canna satinata, trattenuta al calcio da tre fascette, è completato da fornimenti in acciaio color argento vecchio. L'acciarino, anch'esso color argento vecchio, riporta la scritta U.S. SPRINGFIELD.

MLAIC

**1861 SPRINGFIELD
(1861-1865)**

Mod. S.243

Originally made during 1861, in limited quantities, by the "Springfield" Armoury, this replica, authentically reproduces one of America's most historical firearms. More efficient than the earlier smooth bored muskets used by both sides in the American Civil War. It is produced with satin finish barrel, stock with three bands, coin finish colour steel furniture. The lock is finished bright with U.S. SPRINGFIELD stamping's.

Mod.	Cal.	Righe Grooves	Passo Twist mm - inches	Lungh. canna Barrel length mm - inches	Lungh. totale Overall length mm - inches	Peso Weight kg - lbs	Misura palla Ball/bullet size	Blocco pallottiere Our bullet mould Our code
S.243	.58	3	1.200 - 1:48	1.020 - 40 ¹ / ₁₆	1.420 - 55 ³ / ₁₆	4,600 - 10.14	.577 Miniè	USA 309-577
S.273	.69 (17,5 mm)	-	-	1.060 - 41 ¹ / ₄	1.450 - 57 ¹ / ₁₆	4.300 - 9.48	.675 round	USA 306-675





K.210



K.313



S.273

S.243

KITS

Alcuni modelli della nostra produzione sono disponibili nella versione "kit". Con alcune nozioni di base del "fai da te" e un minimo di attrezzatura si può allestire la propria arma in modo personalizzato. L'arma in kit è già stata preassemblata: la canna, non ancora brunita,

è stata sottoposta a un trattamento anti-corrosione e ossidazione; l'acciarino è finito e montato; il calcio richiede la levigatura, la zigrinatura, la tinteggiatura e la lucidatura finale; i fornimenti devono essere sottoposti a pulitura e lucidatura.

KITS

Some of our production models can be supplied in the KIT version. They need some simple "do it yourself" knowledge basis, few tooling and some working hours to complete and finish a "self-custom-made" gun. The KIT gun has

been previously assembled, the barrel is not blued but it goes through an antirust treatment, the lock is assembled and finished, the stock needs to be smoothen, checkered, coloured and oil finished, the metal furniture needs to be polished.

KIT FUCILI / RIFLES KITS			
Code	Modello / Model	Cal.	
K.210	KENTUCKY	Pietra focaia / Flintlock	.32 - .45 - .50
K.213	KENTUCKY	Percussione / Percussion	.32 - .45 - .50
K.222	SCOUT	Pietra focaia / Flintlock	.32 - .45 - .50
K.223	SCOUT	Percussione / Percussion	.32 - .45 - .50
K.226	CUB DIXIE	Percussione / Percussion	.36 - .45 - .50
K.227	CUB DIXIE	Pietra focaia / Flintlock	.36 - .45 - .50
K.219	TRYON "TARGET"	Percussione / Percussion	.45 - .50 - .54
K.224	TRYON "MAPLE"	Percussione / Percussion	.45 - .50 - .54
K.232	JÄGER HUNTER	Pietra focaia / Flintlock	.54
K.233	JÄGER HUNTER	Percussione / Percussion	.54
K.264	FRONTIER CARBINE	Pietra focaia / Flintlock	.50 - .54
K.265	FRONTIER CARBINE	Percussione / Percussion	.50 - .54
K.266	FRONTIER	Pietra focaia / Flintlock	.32 - .36 - .45 - .50 - .54
K.267	FRONTIER	Percussione / Percussion	.32 - .36 - .45 - .50 - .54
K.268	FRONTIER "MAPLE" - Standard	Pietra focaia / Flintlock	.32 - .36 - .45 - .50 - .54
K.269	FRONTIER "MAPLE" - Standard	Percussione / Percussion	.32 - .36 - .45 - .50 - .54
K.275	PENNSYLVANIA	Pietra focaia / Flintlock	.32 - .45
K.270	PENNSYLVANIA	Percussione / Percussion	.32 - .45
K.276	PENNSYLVANIA DIXIE	Pietra focaia / Flintlock	.32 - .45
K.271	PENNSYLVANIA DIXIE	Percussione / Percussion	.32 - .45
K.282	INDIAN TRADE MUSKET	Pietra focaia / Flintlock	20 ga.
K.241	DOPPIETTA / SIDE BY SIDE SHOTGUN "CLASSIC"	Percussione / Percussion	12 ga.
K.247	DOPPIETTA / SIDE BY SIDE SHOTGUN "WATERFOWL"	Percussione / Percussion	10 ga.
K.285	DOPPIETTA / SIDE BY SIDE SHOTGUN "CLASSIC"	Percussione / Percussion	20 ga.
K.293	DOPPIETTA / SIDE BY SIDE SHOTGUN "SLUG"	Percussione / Percussion	12 ga.

KIT PISTOLE / PISTOLS KITS			
Code	Modello / Model	Cal.	
K.255	1763 LEGERE (1766) CHARLEVILLE	Pietra focaia / Flintlock	17,5 mm (.69)
K.256	1777 REVOLUTIONNAIRE	Pietra focaia / Flintlock	17,5 mm (.69)
K.258	1777 CORRIGE' AN IX	Pietra focaia / Flintlock	17,5 mm (.69)
K.292	"AN IX" DRAGOONS	Pietra focaia / Flintlock	17,5 mm (.69)
K.263	1798 AUSTRIAN	Pietra focaia / Flintlock	17,5 mm (.69)
K.261	1809 PRUSSIAN	Pietra focaia / Flintlock	19,05 mm (.75)
K.260	BROWN BESS	Pietra focaia / Flintlock	.75
K.262	BROWN BESS CARBINE	Pietra focaia / Flintlock	.75
K.273	1816 HARPER'S FERRY B N S B N MUDDRN M	Percussione / Percussion	.69 (17,5 mm)
K.274	1816 HARPER'S FERRY	Pietra focaia / Flintlock	.69 (17,5 mm)
K.298	1795 SPRINGFIELD	Pietra focaia / Flintlock	.69 (17,5 mm)



A Otturatore guidato lateralmente e anteriormente
Boltstop prevents firing out of battery

C Otturatore con percussore lanciato
Bolt with inertia firing pin for additional safety

G Congegno per lo sparo a colpo singolo
Single shot device

Calcio e aste in noce
Walnut stock and forend

E Congegno per scaricare l'arma
Unloading latch provides a safer means in which to unload the rifle

H Grilletto funzionante solo ad otturatore chiuso
Trigger will only function with bolt fully in battery

Un'arma improntata sulla sicurezza

PEDERSOLI LIGHTNING*

- A. L'otturatore guidato non può fuoriuscire, neanche per cause accidentali, dalla bascula; lo stesso, inoltre, è stato progettato e realizzato in modo da escludere la percussione della cartuccia se non a chiusura completa.
- B. L'estrattore a molla separata garantisce una maggiore durata e un migliore funzionamento.
- C. Il percussore lanciato costituisce una sicurezza importante: permette, infatti, il trasporto dell'arma anche negli spostamenti a piedi e con cane abbattuto e, pur se con il colpo in canna, assicura che il percussore stesso rimanga staccato dall'innesco della cartuccia, evitando sempre e in ogni modo lo sparo accidentale.
- D. Tacca di mira con alzo a ritto e cursore, regolabile in verticale.
- E. Congegno per scaricare l'arma: consente di scaricare le cartucce non esplose dall'arma, senza che avvenga l'abbattimento del cane sul percussore (Patent pending).
- F. Tubo serbatoio: è stato migliorato rispetto all'originale risolvendo gli inconvenienti della facile usura.
- G. Congegno per lo sparo a colpo singolo. Rispetto all'originale è stata incrementata la sicurezza nell'utilizzo dell'arma stessa, poiché è necessario rilasciare il grilletto prima di potere effettuare il tiro successivo (Patent Pending).
- H. Il grilletto funziona soltanto con l'otturatore completamente chiuso, scongiurando ogni rischio di sparo accidentale.

B Estrattore a molla separata
Extractor with separate spring for a longer service life and more reliable extraction

D Tacca di mira regolabile
Semi-buckhorn rear sight with elevation adjustment



F Serbatoio modificato
Modified magazine provides for reliable loading and feeding

A fast action rifle with new safety features

PEDERSOLI LIGHTNING*

- A.** Bolt is designed and built to ensure that it is full engaged prior to firing of the rifle.
- B.** The extractor has a separate spring, providing more reliable extraction and longer service life.
- C.** Inertia firing pin design provides additional safety by helping to keep the firing pin from striking the primer by any other means than the pulling of the trigger.
- D.** Standard semi-buckhorn rear sight with elevation adjustment.
- E.** Unloading latch provides a safer means in which to unload the rifle. This latch provides a means to unload the rifle while preventing the hammer from striking the firing pin.
- F.** Improved magazine and loading gate for reliable loading and feeding. The magazine (ten cartridges) has been modified from the original by a redesigned cartridge buffer, eliminating loading and feeding problems found in original guns and replicas that follow this design.
- G.** Single shot device for a safer use of the gun (to avoid a potentially unsafe "slam-fire" situation).
- H.** Trigger system has been redesigned to only fire when the bolt is fully in battery.

* Trademark owned by Cimarron Firearms



PEDERSOLI LIGHTNING*

(1884-1902)

Riproduzione di una delle armi lunghe più utilizzate negli anni a cavallo del 1890, oggi molto ambita in alcune specialità del tiro dinamico western. Rispetto al modello statunitense originale, sono state realizzate importanti modifiche alle componenti meccaniche per rendere l'arma più sicura e funzionale. Tale studio ha permesso di mantenere l'aspetto e il fascino del modello progenitore e, contestualmente, di ottenere una più moderna struttura della organizzazione meccanica per rispettare le esigenze del tiratore dei nostri tempi.

Disponibile nella versione **Rifle**, con canna ottagonale oppure tonda lunga 26" e 24", **Carbine** con canna ottagonale da 20" e **Baby Carbine** con canna tonda da 20" collegata al serbatoio tramite una fascetta a doppio collare.

Per ogni versione vengono offerti tre allestimenti diversi: **Standard**, bascula e forni con brunitura nera e calcio in noce; **Premium**, con bascula tartarugata e calcio in noce "semi-fancy" zigrinato; **Deluxe**, con bascula e paragrilletto colore argento vecchio con incisione rifinita a mano e calcio in noce "fancy", zigrinato a passo fine.

PEDERSOLI LIGHTNING*

(1884-1902)

A reproduction of one of the most famous rifles used during the 1890's by cowboys and settlers of the American West and today very desired by Cowboy Action shooters, hunters and collectors.

To the original American model, we made important modifications to the mechanical parts to make the rifle more safe and reliable.

With great care, we retained the fascination, beauty and appearance of the original rifle while at the same time making subtle changes to design out the weaknesses of the original and give today's shooters an accurate and reliable rifle.

*Available in the **Rifle** version with 24" and 26" octagonal or round barrels, in the **Carbine** version with 20" octagonal barrel and **Baby Carbine** with 20" round barrel retained to the magazine by a shaped double ring band.*

*Both Rifle and Carbine are offered with three different finishes: **Standard**: blue action and furniture, walnut stock; **Premium**: case hardened action, semi-fancy walnut checkered stock; **Deluxe**: coin finish colour for the action and the trigger guard, finished by engraving, fancy walnut stock, fine checkering. Both the Rifle and the Carbine versions feature a checkered forend.*



Deluxe model

Standard carbine

Premium model

Standard model

* Trademark owned by Cimarron Firearms

Mod.	Cal.	Righe Grooves	Passo Twist mm - inches	Lungh. canna Barrel length mm - inches	Lungh. totale Overall length mm - inches	Peso Weight Kg - lbs	Canna Barrel
S./V./L.920	.357 Magnum	8	460 - 1:18	508 - 20"	932 - 36 ¹ / ₁₆	2,900 - 6.39	ottagonale / octagonal
S./V./L.920	.44-40 Winch.	6	914 - 1:36	508 - 20"	932 - 36 ¹ / ₁₆	2,900 - 6.39	ottagonale / octagonal
S./V./L.920	.45 Colt	6	400 - 1:16	508 - 20"	932 - 36 ¹ / ₁₆	2,900 - 6.39	ottagonale / octagonal
S./V./L.921	.357 Magnum	8	460 - 1:18	610 - 24"	1.038 - 40 ⁷ / ₈	3,100 - 6.83	ottagonale / octagonal
S./V./L.921	.44-40 Winch.	6	914 - 1:36	610 - 24"	1.038 - 40 ⁷ / ₈	3,100 - 6.83	ottagonale / octagonal
S./V./L.921	.45 Colt	6	400 - 1:16	610 - 24"	1.038 - 40 ⁷ / ₈	3,100 - 6.83	ottagonale / octagonal
S./V./L.922	.357 Magnum	8	460 - 1:18	660 - 26"	1.088 - 42 ³ / ₁₆	3,300 - 7.28	ottagonale / octagonal
S./V./L.922	.44-40 Winch.	6	914 - 1:36	660 - 26"	1.088 - 42 ³ / ₁₆	3,300 - 7.28	ottagonale / octagonal
S./V./L.922	.45 Colt	6	400 - 1:16	660 - 26"	1.088 - 42 ³ / ₁₆	3,300 - 7.28	ottagonale / octagonal
S./V./L.923	.357 Magnum	8	460 - 1:18	660 - 26"	1.088 - 42 ³ / ₁₆	3,300 - 7.28	tonda / round
S./V./L.923	.44-40 Winch.	6	914 - 1:36	660 - 26"	1.088 - 42 ³ / ₁₆	3,300 - 7.28	tonda / round
S./V./L.923	.45 Colt	6	400 - 1:16	660 - 26"	1.088 - 42 ³ / ₁₆	3,300 - 7.28	tonda / round
S./V./L.924	.357 Magnum	8	460 - 1:18	508 - 20"	932 - 36 ¹ / ₁₆	2,900 - 6.39	tonda / round
S./V./L.924	.44-40 Winch.	6	914 - 1:36	508 - 20"	932 - 36 ¹ / ₁₆	2,900 - 6.39	tonda / round
S./V./L.924	.45 Colt	6	400 - 1:16	508 - 20"	932 - 36 ¹ / ₁₆	2,900 - 6.39	tonda / round
S./V./L.925	.357 Magnum	8	460 - 1:18	610 - 24"	1.038 - 40 ⁷ / ₈	3,100 - 6.83	tonda / round
S./V./L.925	.44-40 Winch.	6	914 - 1:36	610 - 24"	1.038 - 40 ⁷ / ₈	3,100 - 6.83	tonda / round
S./V./L.925	.45 Colt	6	400 - 1:16	610 - 24"	1.038 - 40 ⁷ / ₈	3,100 - 6.83	tonda / round

S= Standard - V= Premium - L= Deluxe



S.852

S.870 L.870

ROLLING BLOCK (1868-1890)

Fantastiche riproduzioni di uno dei più famosi e popolari fucili a cartuccia, e grande antagonista dello Sharps. Il particolare sistema di chiusura è considerato uno dei più sicuri, tanto che venne utilizzato in tutto il mondo. Con parti realizzate completamente in acciaio, i Rolling Block sono prodotti in calibri e lunghezze di canna diversi. Tutti i modelli sono predisposti per il montaggio del mirino a tunnel con inserti intercambiabili (pag. 84) e della diottra regolabile in verticale e orizzontale (pagg. 82-83). Le versioni lusso sono caratterizzate da ricche incisioni sulla bascula satinata.

ROLLING BLOCK (1868-1890)

Fantastic reproductions of one of the most popular cartridge guns and great rival of the Sharps in its time. The special lock system, is certainly one of the safest, and was subsequently used all over the world. Metal parts made of stainless steel, produced in various calibers and different barrels lengths. All the models can be mounted with front tunnel sights with interchangeable inserts (page 84) and with Creedmoor sights adjustable in elevation and windage (pages 82-83). The Deluxe versions are characterized by rich engravings on the coin colour finished frame.

ROLLING BLOCK LONG RANGE CREEDMOOR

Mod. S.870 - Standard
Mod. L.870 - Deluxe

Prodotto con canna ottagonale conica, brunita, è caratterizzato da calcio a pistola zigrinata. Tutte le parti sono in acciaio color tartaruga. La versione Deluxe, con bascula e parti in acciaio color argento vecchio, presenta accurate incisioni. L'asta, completata da puntale in German silver, e il calcio sono realizzati in noce selezionata.

ROLLING BLOCK LONG RANGE CREEDMOOR

Mod. S.870 - Standard
Mod. L.870 - Deluxe

This model is produced with octagonal conical blued barrel and walnut stock, characterized by a checkered pistol grip. All parts are made of colour case hardened steel. The Deluxe version, with coin colour finish frame and steel parts, is enriched with accurate engravings. Forend, equipped with German silver cap, and stock are made of selected walnut.

Mod.	Cal.	Righe Grooves	Passo Twist mm - inches	Lungh. canna Barrel length mm - inches	Lungh. totale Overall length mm - inches	Peso Weight kg - lbs	Stecher Set trigger	Diottra Creedmoor	Mirino a tunnel Tunnel sight
Ⓞ A.S.	S./L.852	.45-70	6 460 - 1:18	762 - 30"	1.187 - 46 1/4	4,600 - 10.13	-	-	-
Ⓞ A.S.	S./L.852	.357 Mag.	8 460 - 1:18	762 - 30"	1.187 - 46 1/4	4,800 - 10.57	-	-	-
Ⓞ A.S.	S.865	.45-70	6 460 - 1:18	762 - 30"	1.187 - 46 1/4	4,600 - 10.13	*	-	-
Ⓞ A.S.	S./L.870	.45-70	6 460 - 1:18	762 - 30"	1.187 - 46 1/4	4,700 - 10.35	-	USA 436	USA 455
Ⓞ A.S.	S./L.870	.45-90	6 460 - 1:18	762 - 30"	1.187 - 46 1/4	4,700 - 10.35	-	USA 436	USA 455
Ⓞ A.S.	S./L.870	.357 Mag.	8 460 - 1:18	762 - 30"	1.187 - 46 1/4	4,900 - 10.79	-	USA 436	USA 455



L.870

S.870

S.865

S.865

ROLLING BLOCK SILHOUETTE

Mod. S.865

Nuova versione del fucile Rolling Block, con canna ottagonale conica brunita e con bascula e fornimenti in acciaio tartarugato. L'arma, molto competitiva nel tiro alla Silhouette, da cui prende il nome, è dotata di stecher a doppio grilletto. Il calcio, in legno di noce, è foggiato con la tipica configurazione per il tiro in appoggio: dorso diritto, ampio calcio, impugnatura a pistola con due pannelli laterali zigrinati; l'asta è completata da puntale metallico.

ROLLING BLOCK SILHOUETTE

Mod. S.865

New version of the Rolling Block rifle, with tapered octagonal blue barrel, case hardened frame and metal parts. The rifle is really competitive in the Silhouette shooting, from which the name is taken, equipped with double set trigger. The walnut stock is shaped in the typical configuration used in the off hand shooting as well as for shooting from crossed sticks or bench: high straight comb meets NRA current rules, large butt plate, checkered pistol grip; forend with metal cap.

S.852 L.852

ROLLING BLOCK TARGET

Mod. S.852 - Standard
Mod. L.852 - Deluxe

Prodotto con canna ottagonale conica, brunita e bascula color tartaruga è dotato di tacca di mira a rampa regolabile in verticale e completato da calcio e guardamano in acciaio. Il calcio all'inglese e l'asta sono in noce lucidati a olio. La versione Deluxe è caratterizzata da ricche incisioni sulla bascula. L'asta, completata da puntale in German silver, e il calcio sono in noce selezionato.

ROLLING BLOCK TARGET

Mod. S.852 - Standard
Mod. L.852 - Deluxe

Produced with octagonal, conical blued barrel, case hardened colour frame, is equipped with ramp rear sight adjustable in elevation. Butt plate and trigger guard made of steel. Straight stock and forend made of walnut oil finish. The Deluxe version is characterized by rich engraving on the coin colour finish frame. Forend, equipped with German silver cap, and stock are made of selected walnut.



S.876

**ROLLING BLOCK
SUPER MATCH**

Mod. S.876

Fedele riproduzione del fucile prodotto nel XIX secolo in occasione della famosa competizione internazionale di tiro a lunga distanza, coordinata dalla N.R.A. (National Rifle Association), svoltasi il 26 settembre 1874 a Creedmoor, in Long Island.

Calcio e asta in noce selezionato e zigrynati. Il calcio con impugnatura a pistola è particolarmente adatto per il tiro a lunga distanza. L'asta è completata da puntale in German silver.

**ROLLING BLOCK
SUPER MATCH**

Mod. S.876

Accurate reproduction of the rifle produced in 19th Century on the occasion of the famous international long distance shooting, competition coordinated by N.R.A. (National Rifle Association) on the 26th September of 1874, Creedmoor, Long Island. Stock and forend made of selected walnut, checkered. The pistol grip stock is particularly comfortable for the long distance shooting. The forend is completed with a German silver cap.

S.820 S.821

**ROLLING BLOCK
JOHN BODINE**

**Mod. S.820 - S.821 - Standard
Mod. L.820 - L.821 - Deluxe**

Tra le diverse proposte della Remington dedicate ai tiratori di precisione nella seconda metà dell'Ottocento, ci fu una linea di custom rifles dotati, a richiesta, di stecher.

La Davide Pedersoli è lieta di presentare questa nuova versione di Rolling Block con stecher a due grilletti, che lo rende particolarmente adatto per il tiro di precisione. È prodotto con canna ottagonale pesante brunita anti-riflesso, da 30"/762 mm (S.820), e da 34"/864 mm (S.821). Il calcio a pistola, in noce selezionato, consente una impugnatura confortevole per il tiro alle lunghe distanze; l'asta, anch'essa in noce, è completata con puntale in German silver.

La versione Deluxe è arricchita da incisioni sulla bascula color argento vecchio.

**ROLLING BLOCK
JOHN BODINE**

**Mod. S.820 - S.821 - Standard
Mod. L.820 - L.821 - Deluxe**

To comply with target shooters and hunters requests in the late 1800s, Remington offered custom built rifles equipped, on request, with set triggers. Davide Pedersoli Co. are now pleased to introduce this version of the famous Rolling Block equipped with double set trigger which enhance the use of this rifle in long range target competition. A heavy 30" octagonal barrel with blue matt finish is used on the model S.820 and this same type barrel 34" is on model S.821. The comfortable pistol grip stock and forend are made from selected walnut and the forend has an inlet German silver cap.

The Deluxe version is characterized by an accurate engraving on the coin colour finish frame.

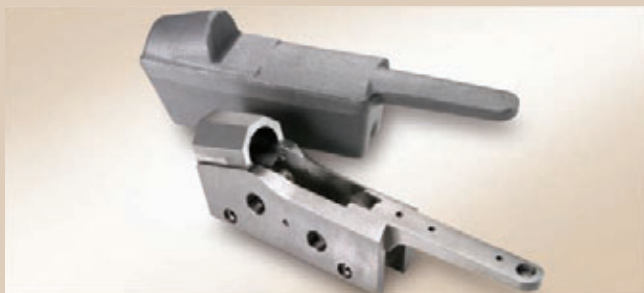



S.822

**ROLLING BLOCK
CREEDMOOR N°2**

Mod. S.822

Negli ultimi decenni dell'Ottocento la personalizzazione dei fucili da tiro alla lunga distanza costituiva una abitudine alquanto diffusa fra i tiratori statunitensi. Si interveniva così sulla lunghezza della canna, sulla forma dell'impugnatura, sui congegni di mira e sull'eventuale installazione di uno scatto servito da stecher.

Ripercorrendo quelle stesse modalità abbiamo realizzato questa nuova versione di Rolling Block per soddisfare le esigenze di numerosi tiratori di tutto il mondo. È caratterizzato da una canna tonda, brunita antiriflesso, e da bascula color argento vecchio. Il calcio a pistola e l'asta sono in noce selezionato e zigrinati.

**ROLLING BLOCK
CREEDMOOR #2**

Mod. S.822

During the last decades of the 1800s the custom making of the guns was a widespread habit among the American shooters. The requests were for different barrel's lengths, special grip shapes, tang sight equipments and whenever possible the set trigger equipment.

Following the same pattern, we made this Rolling Block rifle version to satisfy the exigencies of numerous shooters all over the world. It features a round matt blued barrel, coin finish colour frame, double set trigger. The pistol grip stock and the forend are made of selected checkered walnut.

S.822

USA 544

BORESCOPE

USA 544 - Borescope

Pratico accessorio in ottone per ispezionare l'interno della camera e della canna dei fucili a cartuccia calibro .45 o superiori. Dispone di una lente d'ingrandimento 4X e misura 175 mm (7") di lunghezza. Il punto di messa a fuoco si configura a una distanza di 125 mm (5") dalla fine del tubo.

BORESCOPE

USA 544 - Borescope

This borescope enters .45 and .50 caliber barrels and provides a sharp clear view of internal chamber and barrel conditions. Scope is 7" (175 mm) long and has 4X magnification. Focal point is 5" (125 mm) from end of brass tube so it provides useful inspection into smaller caliber barrels as well. Powder fouling, leading and damaged rifling are easily seen. To use, point open end of barrel towards a bright light.

USA 544



Mod.	Cal.	Righe Grooves	Passo Twist mm - inches	Lungh. canna Barrel length mm - inches	Lungh. totale Overall length mm - inches	Peso Weight kg - lbs	Stecher Set trigger	Dioftra Creedmoor	Mirino a tunnel Tunnel sight
S.820	.45-70	6	460 - 1:18	762 - 30	1.190 - 46 ⁷ / ₈	5,400 - 11.89	•	USA 430	USA 469-R
S.820	.45-90	6	460 - 1:18	762 - 30	1.190 - 46 ⁷ / ₈	5,400 - 11.89	•	USA 430	USA 469-R
S.821	.45-70	6	460 - 1:18	864 - 34	1.292 - 50 ⁷ / ₈	5,700 - 12.55	•	USA 430	USA 469-R
S.821	.45-90	6	460 - 1:18	864 - 34	1.292 - 50 ⁷ / ₈	5,700 - 12.55	•	USA 430	USA 469-R
S.822	.45-70	6	460 - 1:18	762 - 30	1.170 - 46 ¹ / ₈	4,200 - 9.25	•	USA 430	USA 469-R
S.876	.45-70	6	460 - 1:18	864 - 34	1.292 - 50 ⁷ / ₈	5,400 - 11.89	•	USA 436	USA 455
S.876	.45-90	6	460 - 1:18	864 - 34	1.292 - 50 ⁷ / ₈	5,400 - 11.89	•	USA 436	USA 455



S.812

ROLLING BLOCK SPORTING

Mod. S.812

Realizzato con canna tondo-conica brunita e con le altre parti in acciaio tartarugate, è dotato di tacca di mira regolabile. È disponibile in diversi calibri idonei all'impiego venatorio.

ROLLING BLOCK SPORTING

Mod. S.812

Produced with a round barrel, blue finish and the metal parts case hardened colour. Equipped with adjustable rear sight is available in different calibers idoneous for the hunting.

S.813

ROLLING BLOCK BABY CARBINE

Mod. S.813

Carabina estremamente maneggevole è prodotta con canna tondo-conica brunita e tutte le parti in acciaio color tartaruga. È dotata di tacca di mira alto e mirino regolabili.

ROLLING BLOCK BABY CARBINE

Mod. S.813

Extremely handy rifle, produced with a round barrel, blue finish, metal parts case hardened colour. Equipped with adjustable rear sight and front sight.

S.874

S.874

ROLLING BLOCK N°1 SPORTING RIFLE

Mod. S.874

Riproduzione di uno dei primi fucili con azione Rolling Block destinati al tiro di precisione. Divenne popolare anche perché fu utilizzato dal generale George Armstrong Custer nelle battute di caccia al bison. È realizzato con canna ottagonale, calcio all'inglese e asta in noce selezionato. L'asta è completata con puntale in acciaio tartarugato.

ROLLING BLOCK #1 SPORTING RIFLE

Mod. S.874

This is a hunting rifle popular with buffalo hunters, scouts and famous Old West personalities like General George Armstrong Custer, who used this rifle on his Black Hills expedition in 1874 where he was photographed with an elk and a grizzly bear that he had taken with it. It is produced with octagonal barrel, oil finish walnut stock and forend with hardened steel cap.

Mod.	Cal.	Righe Grooves	Passo Twist mm - inches	Lungh. canna Barrel length mm - inches	Lungh. totale Overall length mm - inches	Peso Weight kg - lbs	Stecher Set trigger	Dioftra Creedmoor	Mirino a tunnel Tunnel sight
S.812	.30-30 Winch.	6	306 - 1:12	711 - 28	1.136 - 44 ¹ / ₄	4,000 - 8.81	-	-	-
S.812	.38-55 Winch.	6	460 - 1:18	711 - 28	1.136 - 44 ¹ / ₄	3,900 - 8.59	-	-	-
S.813	.44-40 Winch.	6	914 - 1:36	508 - 20	933 - 36 ¹ / ₄	3,400 - 7.49	-	-	-
S.813	.45 Long Colt	6	400 - 1:16	508 - 20	933 - 36 ¹ / ₄	3,400 - 7.49	-	-	-
S.813	.357 Mag.	8	460 - 1:18	508 - 20	933 - 36 ¹ / ₄	3,600 - 7.93	-	-	-
S.874	.45-70	6	460 - 1:18	762 - 30	1.170 - 46 ¹ / ₁₆	4,600 - 10.13	USA 436	USA 455	USA 455
S.874	.45-90	6	460 - 1:18	762 - 30	1.170 - 46 ¹ / ₁₆	4,600 - 10.13	USA 436	USA 455	USA 455



L.890 L.892 S.890 S.892
KODIAK MARK IV

Mod. S.890 - Standard
Mod. L.890 - Deluxe
Mod. S.892 - Standard
Mod. L.892 - Deluxe

Riproduzione fedele del famoso fucile a retrocarica "Colt Double", prodotto nel 19° secolo, il Kodiak Mark IV, non è più solo un pezzo da museo, ma un'arma accessibile a ogni collezione e allo stesso tempo ideale per battute di caccia. Ottimo il sistema di mira, garantito da mirino e da tacca di mira a fogliette, con inserimento a coda di rondine; la canna, di forma tondo-conica, è in acciaio brunita. Il calcio, in noce selezionato, è zigrinato e lucidato a olio.

Le versioni nei calibri 8x57JRS e 9,3x74R rendono il Kodiak un ottimo compagno per le battute di caccia al cinghiale e altri ungulati. In queste versioni si è particolarmente provveduto a ridurre il peso e a rendere il fucile estremamente bilanciato. Su richiesta, tutti i modelli sono disponibili con canne intercambiabili in calibro 20 (S./L.891-S./L.893).

(1879-1885 c.)

La versione Delux è arricchita da incisioni su bascula e parti in acciaio color argento vecchio.

USA 387
VALIGETTA
USA 387

Valigetta per doppietta a retrocarica.
 Misure (interne): 720x170 mm

Mod.	Cal.	Righe Grooves	Passo Twist		Lungh. canna Barrel length		Lungh. totale Overall length		Peso Weight	
			mm	- inches	mm	- inches	mm	- inches	kg	- lbs
S./L.890	45-70	6	460	- 1:18	610	- 24	1.030	- 40 ¹ / ₂	4,600	- 10.13
S./L.892	45-70	6	460	- 1:18	560	- 22	980	- 38 ² / ₅	4,400	- 9.69
S./L.892	9,3x74 R	4	360	- 1:14	560	- 22	980	- 38 ² / ₅	4,400	- 9.69
S./L.892	8x57 JRS	4	250	- 1:10	560	- 22	980	- 38 ² / ₅	4,400	- 9.69

KODIAK MARK IV

(1879-1885 c.)

Mod. S.890 - Standard
Mod. L.890 - Deluxe
Mod. S.892 - Standard
Mod. L.892 - Deluxe

Faithful reproduction of the famous "Colt Double" breech loading double rifle produced on the 19th century, the Kodiak Mark IV is no museum piece, but an accessible gun for collectors and satisfied hunters. Very good sighting

with the double-leaf rear sight in a dovetail, the tapered round barrels are made of blued steel. The stock is made of selected walnut, checkered and oil finished.

The versions in 8x57JRS and 9,3x74R calibers make the Kodiak an excellent choice for hunting. For these models we have mostly worked on weight reduction and gun balance.

Upon request, all models are available with interchangeable barrels in 20 gauge (S./L.891 - S./L.893).

The Deluxe version is characterized by an accurate engraving on the coin colour finished frame and metal fittings.

CASE
USA 387

Case for double barrel shotgun.
 Measures (inside): 28³/₈" x 6¹/₁₆"
 (720x170 mm)



SHARPS

“SHARPS PTD”, un nome che ha fatto sognare tiratori e collezionisti di tutto il mondo.

In seguito alle richieste dei nostri distributori e tiratori abbiamo iniziato, già da parecchi anni, la produzione di una delle armi più famose e apprezzate del periodo della Guerra Civile Americana.

La nostra gamma di fucili Sharps, che presentiamo sempre con orgoglio, comprende tanto le versioni a cartuccia di carta quanto quelle a cartuccia metallica. Tutti i modelli sono prodotti utilizzando i migliori materiali e le tecnologie più moderne, per ottenere un'arma di assoluta qualità. Tutti i componenti principali sono realizzati da metalli forgiati al fine di assicurare una maggior resistenza, e la rigatura delle canne, ottenuta per brocciatura, garantisce sempre ottimi risultati nel tiro.

Tutti i modelli, inoltre, sono predisposti per il montaggio della diottra (pag. 82-83) e, a eccezione dei modelli militari, per l'applicazione del mirino a tunnel con inserti intercambiabili (pag. 84).

SHARPS

“SHARPS PTD” *The name that shooters and collectors all over the world dream about.*

To satisfy the request of our customers and shooters, some years ago, we started a project for the production of one of the most famous rifles of the American Civil War era.

The range of rifles includes all the most significant versions among the paper cartridge and the metal cartridge models. For all models we have used the best materials and latest techniques, so to ensure a top quality product. The most important parts are machined from forged metals for maximum durability and strength and the deep rifling is broached and ensures excellent results in long distance shooting.

All the models are drilled and tapped to install the Creedmoor sights (pages 82-83) and the front tunnel sights with interchangeable inserts (page 84), except for the military models.

S.755 S.760 S.766

1859-1863 SHARPS

(1859-1866)

1863 Sharps Sporting

Mod. S.755

1859 Sharps Infantry

Mod. S.760

1859 Sharps Berdan

Mod. S.761

1859 Sharps Cavalry

Mod. S.766

Fra gli Sharps a cartuccia di carta (1859 e 1863) troviamo sia il modello **Sporting**, con canna ottagonale color damasco, mirino regolabile e stecher, sia i modelli **Infantry** e **Cavalry** con canna tonda brunita, trattenuta da fascette, mirino fisso e tabacchiera.

Del modello **Infantry** è disponibile la versione **Berdan**, dotata di stecher a due grilletti. Tutti i modelli, inoltre, presentano una tacca di mira con alzo e cursore.

1859-1863 SHARPS

(1859-1866)

1863 Sharps Sporting

Mod. S.755

1859 Sharps Infantry

Mod. S.760

1859 Sharps Berdan

Mod. S.761

1859 Sharps Cavalry

Mod. S.766

*Among the paper cartridge Sharps rifles (1859 & 1863 models) you can find the **Sporting** model with octagonal barrel rust brown finish colour, adjustable front sight and set trigger, the **Infantry** and **Cavalry** models with blue round barrel, kept by bands, have fixed front sight and patchbox on the stock. Of the **Infantry** model there is also the **Berdan** version, equipped with double set trigger. All the models are equipped with graduated rear sight with sliding plate.*



S.763

1862 CONFEDERATE SHARPS CARBINE (1862-1864)

Mod. S.763

Fra le armi prodotte negli arsenali della Confederazione, durante la guerra fra gli stati d'America, vi era una carabina mutuata dal modello 1859 Sharps e fabbricata in circa duemila esemplari dalla S.C. Robinson Arms Manufactory di Richmond, in Virginia, dal 1862 al 1863. L'arma differiva dallo Sharps per l'assenza del congegno di distribuzione degli inneschi nella parte superiore della cartella e per i fornimenti in ottone. La nostra replica è destinata agli appassionati di armi americane e alle rievocazioni storiche delle battaglie della guerra di secessione.

1862 CONFEDERATE SHARPS CARBINE (1862-1864)

Mod. S.763

Among the guns produced in the Confederate arsenals during the American Civil War, there was a carbine borrowed from the 1859 Sharps model and produced in about two thousand units by the "S.C. Robinson Arms Manufactory" in Richmond, Virginia from 1862 to 1863. The rifle was different from the Sharps for the absence of the automatic primer dispenser device in the upper part of the frame. Our reproduction gun is addressed to the fond shooters of American guns and to the historical reenactors of the Civil War battles.

S.763

S.755

S.760

USA 517

BOSSOLI IN OTTONE PER 1859 & 1863 SHARPS

- USA 517-451: per calibro .45 (palla stile originale)
- USA 517-54A: per calibro .54 (palla stile moderno)
- USA 517-54B: per calibro .54 (palla stile originale)

BRASS CARTRIDGE CASING FOR 1859 & 1863 SHARPS

- USA 517-451: for .45 caliber
- USA 517-54A: for .54 caliber (modern design bullet)
- USA 517-54B: for .54 caliber (original design bullet)



Mod.	Cal.	Righe Grooves	Passo Twist	Lungh. canna Barrel length	Lungh. totale Overall length	Peso Weight	Slecher Set trigger	Dioftra Creedmoor	Mirino a tunnel Tunnel sight
			mm - inches	mm - inches	mm - inches	kg - lbs			
⊙ A.S.	S.755	.45	6 1:18	813 - 32	1.240 - 48 ⁷ / ₈	4,900 - 10.79	•	-	-
⊙ A.S.	S.755	.54	6 1:200	1:48	813 - 32	1.240 - 48 ⁷ / ₈	4,600 - 10.13	•	-
⊙ A.S.	S.760	.54	6 1:200	1:48	760 - 30	1.190 - 46 ⁷ / ₈	4,300 - 9.47	-	-
⊙ A.S.	S.761	.54	6 1:200	1:48	760 - 30	1.190 - 46 ⁷ / ₈	4,300 - 9.47	•	-
⊙ A.S.	S.763	.54	6 1:200	1:48	560 - 22	985 - 38 ³ / ₁₆	3,700 - 8.15	-	-
⊙ A.S.	S.766	.54	6 1:200	1:48	560 - 22	995 - 39 ¹ / ₁₆	3,800 - 8.37	-	-



S.791

S.790 S.791 S.775 S.780

1874 SHARPS

1874 Sharps Infantry
Mod. S.790

1874 Sharps Sniper
Mod. S.791

1874 Sharps Cavalry
Mod. S.775

1874 Sharps Sporting
Mod. S.780 - Standard

Fra gli Sharps a cartuccia metallica troviamo sia il modello **Sporting**, con canna ottagonale brunita, mirino regolabile e stecher, sia i modelli di

(1871-1881)

derivazione militare **Infantry** e **Cavalry** con mirino fisso e canna tonda, brunita, trattenuta da fascette. Del modello **Infantry**, il cui calcio è dotato di tabacchiera, è disponibile anche la versione **Sniper**, che si differenzia per la presenza dello stecher a doppio grilletto. Tutti i modelli, inoltre, presentano una tacca di mira con alzo e cursore e sono predisposti per il montaggio della diottra (pagg. 82-83). Sullo Sharps Sporting è possibile applicare il mirino a tunnel con inserti intercambiabili (pag. 84).

1874 SHARPS

(1871-1881)

1874 Sharps Infantry
Mod. S.790

1874 Sharps Sniper
Mod. S.791

1874 Sharps Cavalry
Mod. S.775

1874 Sharps Sporting
Mod. S.780 - Standard

Among the Sharps 1874 models you can find the **Sporting** model with octagonal blued barrel, adjustable front sight and

double set trigger. The **Infantry** and **Cavalry** models have a fixed front sight and round barrel retained by steel bands. **Infantry** model has a patchbox in the stock while the **Sniper** model is equipped with double set trigger. All the models are equipped with graduated rear sight with sliding plate and are drilled and tapped to mount a Creedmoor sight (pages 82-83). The **Sporting** model can be completed with tunnel front sight with interchangeable inserts (page 84).



S.771

S.780

S.790

S.775

S.771

1874 SHARPS BUSINESS

Mod. S.771

La versione "essenziale" del grande Sharps Sporting, di cui mantiene le principali caratteristiche di precisione e modularità.

È stato realizzato soprattutto per coloro che cercano nel fucile il fedele compagno di una vita rude e pragmatica. Il calcio in noce è completo di un calciolo zigrinato antiscivolo, le parti metalliche sono sabbiate antiriflesso e color tartaruga.

1874 SHARPS BUSINESS

Mod. S.771

It is the basic model of the great Sharps Sporting, keeping the main technical characteristics and especially the precision. It has been made for those who look for a faithful, strong, practical lifetime companion.

Walnut stock complete with no slipping checkered butt stock. Coated sanded metal parts, case hardened colour.



Mod.	Cal.	Righe Grooves	Passo Twist mm - inches	Lungh. canna Barrel length mm - inches	Lungh. totale Overall length mm - inches	Peso Weight kg - lbs	Slecher Set trigger	Diottra Creedmoor	Mirino a tunnel Tunnel sight
⊙	S.771	.45-70	6 460 - 1:18	813 - 32	1.240 - 48 ¹ / ₂	4,800 - 10.57	•	-	-
⊙	S.775	.45-70	6 460 - 1:18	560 - 22	995 - 39 ¹ / ₂	3,800 - 8.37	-	-	-
⊙	S.780	.45-70	6 460 - 1:18	813 - 32	1.240 - 48 ¹ / ₂	4,800 - 10.57	•	-	-
⊙	S.780	.45-90	6 460 - 1:18	813 - 32	1.240 - 48 ¹ / ₂	4,800 - 10.57	•	-	-
⊙	S.790	.45-70	6 460 - 1:18	760 - 30	1.190 - 46 ¹ / ₂	4,400 - 9.69	-	-	-
⊙	S.791	.45-70	6 460 - 1:18	760 - 30	1.190 - 46 ¹ / ₂	4,400 - 9.69	•	-	-



S.776

**1874 SHARPS
BILLY DIXON**
Mod. S.776

In nome del giovane e famoso scout che il 27 giugno 1874, ad Adobe Walls in Texas, in prossimità del Canadian River, colpì un indiano Kiowa a 1.538 yards, utilizzando il suo Sharps. Quel giorno Billy Dixon e 27 cacciatori di bisonti, erano circondati da oltre 500 Kiowa e Comanche sponnati dal loro "uomo della medicina", che li aveva convinti di essere invulnerabili alle pallottole dei "bianchi". Prodotto con canna ottagonale conica, è realizzato con calcio in noce selezionato e asta con puntale in German silver; calcio e asta sono zigrinati e lucidati a tampone, secondo i vecchi sistemi delle armi pregiate.

**1874 SHARPS
BILLY DIXON**
Mod. S.776

In the name of the young and famous scout, who hit a Kiowa warrior at 1538 yards, shooting with his Sharps on June 27, 1874 at Adobe Walls, Texas. Billy Dixon and 27 buffalo hunters were surrounded by more than 500 Kiowa and Comanche warriors, spurred by their "medicine man" who convinced them they were invulnerable at the "white" shots. Produced with octagonal conical barrel, selected walnut stock and forend with German silver cap, checkered and oil finished following the old system used for valued guns.

S.774

**1874 SHARPS
BUFFALO**
Mod. S.774

Prodotto per i tiratori del nuovo Millennio il modello Sharps "Buffalo" racchiude tutte le caratteristiche richieste dai tiratori di precisione: canna pesante, calcio con impugnatura a pistola, e stecher. L'asta, completata con puntale in German silver, e il calcio sono realizzati in noce selezionato.

**1874 SHARPS
BUFFALO**
Mod. S.774

Produced for the shooters of the "New Millennium", the Sharps "Buffalo" possesses all the characteristics for target shooting: heavy barrel, pistol grip stock with great development for an improved adhesion to the shoulder and double set trigger. Forend, equipped with German silver cap, and stock are made of selected walnut.



S.792

1874 SHARPS CREEDMOOR N° 2

Mod. S.792

Versione del fucile Sharps realizzata per i *middle range shooters*, caratterizzata da canna tonda brunita anti-riflesso e da bascula color argento vecchio. Il calcio a pistola e l'asta sono in noce selezionato e zigrinati.

1874 SHARPS CREEDMOOR #2

Mod. S.792

New version of the famous Sharps rifle, designed to excel as a "Mid-Range" or "Silhouette" target rifle. The round barrel has a blue matt finish and the frame has a coin colour finish. The pistol grip stock and forend are made from selected checkered walnut.

Mod.	Cal.	Righe Grooves	Passo Twist		Lung. canna Barrel length		Lung. totale Overall length		Peso Weight	Stecher Set trigger	Dioftra Creedmoor	Mirino a tunnel Tunnel sight
			mm	- inches	mm	- inches	mm	- inches				
S.774	.45-70	6	460	- 1:18	762	- 30	1.190	- 46 ¹ / ₈	5,800	- 12.77	•	USA 465 USA 469-R
S.774	.45-90	6	460	- 1:18	762	- 30	1.190	- 46 ¹ / ₈	5,800	- 12.77	•	USA 465 USA 469-R
S.774	.45-110	6	460	- 1:18	762	- 30	1.190	- 46 ¹ / ₈	5,800	- 12.77	•	USA 465 USA 469-R
S.774	.45-120	6	460	- 1:18	762	- 30	1.190	- 46 ¹ / ₈	5,800	- 12.77	•	USA 465 USA 469-R
S.776	.45-70	6	460	- 1:18	813	- 32	1.240	- 48 ⁷ / ₈	4,900	- 10.79	•	-
S.776	.45-90	6	460	- 1:18	813	- 32	1.240	- 48 ⁷ / ₈	4,900	- 10.79	•	-
S.792	.45-70	6	460	- 1:18	762	- 30	1.190	- 46 ¹ / ₈	4,600	- 10.13	•	USA 430 USA 469-R
S.792	.45-90	6	460	- 1:18	762	- 30	1.190	- 46 ¹ / ₈	4,600	- 10.13	•	USA 430 USA 469-R

©



S.782

S.788

**1874 SHARPS
LONG RANGE**

Mod. S.788

Fedele riproduzione dello Sharps Long Range Rifle ideato nel dicembre 1876, riconvertendo fucili dotati di canna da 32" (813 mm) con canne da 34" (864 mm). In un primo tempo venne prodotto con grilletto singolo e solo nel febbraio 1879 ne vennero realizzati un centinaio di pezzi con stecher a doppio grilletto. Il calcio e l'asta sono in noce selezionato e zigrinati. Il calcio con impugnatura a pistola e guanciaie ne garantiscono la stabilità di tiro. L'asta è completata con puntale in German silver.

S.782

**1874 SHARPS
SILHOUETTE**

Mod. S.782 - Standard

Versione del modello Sporting realizzata con calcio a pistola e asta in noce.

**1874 SHARPS
LONG RANGE**

Mod. S.788

Accurate reproduction of the rifle Sharps Long Range model made in December of 1876, converting rifles with 32" (813 mm) barrels length to 34" (864 mm). At the beginning it was produced with single trigger, only in February of 1879 some hundred pieces have been made with double set trigger. Stock and forend are made of selected walnut, checkered. The stock with pistol grip and cheek piece enables the shooting stability. The forend is completed with a German silver cap.

**1874 SHARPS
SILHOUETTE**

Mod. S.782 - Standard

Version of Sporting model produced with walnut pistol grip stock and forend.

S.789

**1874 SHARPS
QUIGLEY SPORTING**

Mod S.789

Questo modello di fucile Sharps, nasce originariamente dalla trasformazione di un modello da cavalleria di cui mantiene la tabacchiera e il porta-anello per la sella. Il calcio all'inglese e l'asta, completata con puntale in German silver, sono in noce selezionato, zigrinati e lucidati a olio.

**1874 SHARPS
QUIGLEY SPORTING**

Mod S.789

This Sharps rifle model comes originally from the transformation of a Cavalry model of which it keeps the patchbox and the saddle ring. The stock and the forend in selected walnut, German silver cap, are checkered and oil finished.

Mod.	Cal.	Righe Grooves	Passo Twist mm - inches	Lungh. canna Barrel length mm - inches	Lungh. totale Overall length mm - inches	Peso Weight kg - lbs	Stecher Set trigger	Dietro Creedmoor	Mirino a tunnel Tunnel sight
S.770	.45-70	6	460 - 1:18	864 - 34	1.290 - 50 ³ / ₁₆	6,100 - 13.44	•	USA 465	USA 469-R
S.770	.45-90	6	460 - 1:18	864 - 34	1.290 - 50 ³ / ₁₆	6,100 - 13.44	•	USA 465	USA 469-R
S.770	.45-110	6	460 - 1:18	864 - 34	1.290 - 50 ³ / ₁₆	6,100 - 13.44	•	USA 465	USA 469-R
S.770	.45-120	6	460 - 1:18	864 - 34	1.290 - 50 ³ / ₁₆	6,100 - 13.44	•	USA 465	USA 469-R
S.770	.50-90	6	660 - 1:26	864 - 34	1.290 - 50 ³ / ₁₆	5,900 - 12.99	•	USA 465	USA 469-R
S.782	.45-70	6	460 - 1:18	813 - 32	1.240 - 48 ⁷ / ₁₆	4,800 - 10.57	•	-	-
S.782	.45-90	6	460 - 1:18	813 - 32	1.240 - 48 ⁷ / ₁₆	4,800 - 10.57	•	-	-
S.788	.45-70	6	460 - 1:18	864 - 34	1.290 - 50 ³ / ₁₆	5,500 - 12.11	•	-	USA 455
S.788	.45-90	6	460 - 1:18	864 - 34	1.290 - 50 ³ / ₁₆	5,500 - 12.11	•	-	USA 455
S.788	.45-110	6	460 - 1:18	864 - 34	1.290 - 50 ³ / ₁₆	5,500 - 12.11	•	-	USA 455
S.788	.45-120	6	460 - 1:18	864 - 34	1.290 - 50 ³ / ₁₆	5,500 - 12.11	•	-	USA 455
S.788	.50-90	6	660 - 1:26	864 - 34	1.290 - 50 ³ / ₁₆	5,400 - 11.89	•	-	USA 455



**S.770****1874 SHARPS BOSS****Mod. S.770**

Questa versione nasce appositamente per la nuova "Era" e, nella nuova "Era" vuole portare quei vecchi valori di un millennio di storia e di scoperte e quello "spirito del vecchio West" che non fu solo una caratteristica dell'America dell'Ottocento, ma che divenne desiderio di libertà per tutto il mondo.

Prodotto con canna ottagonale pesante con scanalatura Hartford, calcio all'inglese e asta, completata con puntale in German silver, in noce selezionato, è arricchito da incisioni in oro sulla canna SPIRIT OF THE OLD WEST e sulla bascula BOSS GUN.

1874 SHARPS BOSS**Mod. S.770**

This version is expressly created for the new "Era" and in the new "Era" it wants to take the old values of a millennium of history and discoveries, and that "spirit of the Old West" that was not only a characteristic of the 1800's in America, but that became a wish of freedom for the whole world.

Produced with octagonal heavy barrel with Hartford collar, best grade walnut stock, forend with German silver cap. Gold inlaid on the barrel "SPIRIT OF THE OLD WEST", and "BOSS GUN" on the frame makes this rifle unique!

S.795**1874 SHARPS COMPETITION
(1871-1881)****Mod. S.795**

Destinato al tiro di precisione fino alla distanza di 1000 yards, il nuovo Sharps Competition è allestito con calciatura con dorso diritto, un ampio calciolo e impugnatura a pistola con pannelli zigrinati, caratteristiche che lo rendono idoneo anche alle posizioni di tiro a terra. La bascula, il sottoguardia e la leva di armamento presentano una finitura bianca nichelata. L'arma è prodotta con canna ottagonale pesante con scanalatura Hartford. Dotata di tacca di mira e mirino a tunnel con inserti intercambiabili, è predisposta per l'applicazione della diottra.

**1874 SHARPS COMPETITION
(1871-1881)****Mod. S.795**

For the target shooting up to 1000 yards, the new Sharps Competition has a high comb at the stock, a wide butt plate and the checkered pistol grip, features that are ideal also for the prone position. The frame, the trigger plate and the lever have a coin colour finish. The rifle is produced with heavy octagonal barrel with Hartford collar. Equipped with rear sight and tunnel front sight with interchangeable inserts, it is drilled and tapped to mount a Creedmoor tang sight.

Mod.	Cal.	Righe Grooves	Passo Twist		Lungh. canna Barrel length		Lungh. totale Overall length		Peso Weight		Stecher Set trigger	Diottra Creedmoor	Mirino a tunnel Tunnel sight
			mm	- inches	mm	- inches	mm	- inches	kg	- lbs			
S.789	.45-70	6	460	- 1:18	864	- 34	1.290	- 50 ³ / ₁₆	6,000	- 13.21	*	-	-
S.789	.45-90	6	460	- 1:18	864	- 34	1.290	- 50 ³ / ₁₆	6,000	- 13.21	*	-	-
S.789	.45-110	6	460	- 1:18	864	- 34	1.290	- 50 ³ / ₁₆	6,000	- 13.21	*	-	-
S.789	.45-120	6	460	- 1:18	864	- 34	1.290	- 50 ³ / ₁₆	6,000	- 13.21	*	-	-
S.789	.50-90	6	660	- 1:26	864	- 34	1.290	- 50 ³ / ₁₆	5,800	- 12.77	*	-	-
S.795	.45-70	6	460	- 1:18	864	- 34	1.290	- 50 ³ / ₁₆	5,900	- 12.99	*	-	USA 469-R
S.795	.45-90	6	460	- 1:18	864	- 34	1.290	- 50 ³ / ₁₆	5,900	- 12.99	*	-	USA 469-R

©



L.780 LL.780

1874 SHARPS SPORTING

Mod. L.780 - Deluxe
Mod. LL.780 - Extra Deluxe

Magnifiche versioni dello Sharps Sporting con parti in acciaio colore argento vecchio e puntale dell'astina in German silver. Con le calciature selezionate, le perfette incassature, le accurate incisioni e i rimessi in oro sulla bascula del modello Extra Deluxe, questi fucili diventano dei classici esemplari da collezione.

1874 SHARPS SPORTING

Mod. L.780 - Deluxe
Mod. LL.780 - Extra Deluxe

Magnificently versions of the Sharps Sporting rifle with coin finish colour frame and steel parts and a forend cap of German silver. The selected walnut stock with perfect inlitting, the accurate engravings and gold inlays on the frame of Extra Deluxe model made these rifles real collection pieces.

LL.782

SHARPS SILHOUETTE
"PTESAN-WI"

Mod. LL.782 - Extra Deluxe

Splendido esemplare del fucile Sharps Silhouette, arricchito da incisioni e preziosità con rimessi in oro e argento. Questo modello rappresenta un omaggio alla cultura e alla sacralità degli Indiani d'America. Con alcuni importanti simboli abbiamo voluto ricordare la nascita e la vita dei Lakota e il dono della Sacra Pipa, quando per volere del Grande Spirito (Wakan-Tanka) un animale si trasformò nella Donna-Bisonte Bianco (Ptesan-Wi) per portare questo importante segno di pace e di religiosità. I simboli incisi sull'arma rappresentano ideografie nelle pitture su tende, armi e suppellettili comuni a tutti gli indiani delle praterie.

Versione limitata e numerata da 1 a 100.

SHARPS SILHOUETTE
"PTESAN-WI"

Mod. LL.782 - Extra Deluxe

Splendid model of the Sharps Silhouette rifle, enriched with accurate engravings and made more precious with gold and silver inlays. This model represents a homage to the culture of the American Indians. With some important symbols we wanted to remind the birth and the life of Lakotas and the gift of the Sacred Pipe when for the Great Spirit Wakan-Tanka's will an animal self-transformed into a Woman-White Bison "Ptesan-Wi" to carry an important sign of peace and religiousness. The symbols engraved on the gun represent copies of the paintings on the tents, arms and common objects to all the American Indians of the plains.

Limited and numbered version 1-100.



SHARPS SILHOUETTE

Mod. LX.782 - Deluxe

Versione Deluxe con bascula e parti in acciaio color argento vecchio, arricchite da incisioni.

L'asta, completata da puntale in German silver, e il calcio sono realizzati in noce selezionato.

SHARPS SILHOUETTE

Mod. LX.782 - Deluxe

Deluxe version, enriched with engravings on the coin colour finished frame and steel parts.

Forend, equipped with German silver cap, and stock are made of selected walnut.

Mod.	Cal.	Righe Grooves	Passo Twist		Lungh. canna Barrel length		Lungh. totale Overall length		Peso Weight		Stecher Set trigger	Diafra Creedmoor	Mirino a tunnel Tunnel sight
			mm	- inches	mm	- inches	mm	- inches	kg	- lbs			
L.780	.45-70	6	460	- 1:18	813	- 32	1.240	- 48 1/2	4,900	- 10.79	•	USA 465	USA 455
L.780	.45-90	6	460	- 1:18	813	- 32	1.240	- 48 1/2	4,900	- 10.79	•	USA 465	USA 455
LL.780	.45-70	6	460	- 1:18	813	- 32	1.240	- 48 1/2	5,200	- 11.45	•	USA 431	USA 469-R
LL.780	.45-90	6	460	- 1:18	813	- 32	1.240	- 48 1/2	5,200	- 11.45	•	USA 431	USA 469-R
LX.782	.45-70	6	460	- 1:18	813	- 32	1.240	- 48 1/2	4,900	- 10.79	•	USA 465	USA 455
LX.782	.45-90	6	460	- 1:18	813	- 32	1.240	- 48 1/2	4,900	- 10.79	•	USA 465	USA 455
LL.782	.45-70	6	460	- 1:18	813	- 32	1.240	- 48 1/2	5,200	- 11.45	•	USA 431	USA 426
LL.782	.45-90	6	460	- 1:18	813	- 32	1.240	- 48 1/2	5,200	- 11.45	•	USA 431	USA 426



SPECIAL



EDITIONS





S.906

S.905 S.910 S.900

SPRINGFIELD TRAPDOOR

Carbine

Mod. S.900 - Standard
Mod. L.900 - Deluxe
Mod. LL.900 - Extra Deluxe

Rifle

Mod. S.905 - Standard
Mod. L.905 - Deluxe
Mod. LL.905 - Extra Deluxe

Officer

Mod. S.910 - Standard
Mod. L.910 - Deluxe
Mod. LL.910 - Extra Deluxe

Al termine della Guerra Civile (1865), il dipartimento della guerra dovette sostituire gli eccellenti moschetti ad avancarica con armi a cartuccia metallica. Tra il 1865 e il 1866 apparve la prima trasformazione di uno Springfield ad avancarica realizzata da Allin e nel 1868 nacque il primo "Rifle Trapdoor", ulteriormente modificato nel 1870; tre anni dopo un nuovo fucile in calibro .45-70 diede la risposta a tutte le esigenze. Nei vent'anni che seguirono furono pro-

dotte cospicue quantità dello Springfield Trapdoor, fra le quali numerose versioni a canna liscia, per cadetti, per il tiro di precisione e circa cinquecento destinate agli Ufficiali. Lo Springfield Trapdoor tipica arma dei soldati americani, tra i quali il generale Custer, era in dotazione alle truppe anche durante la guerra ispano-americana (1898-1899). La Davide Pedersoli ha il piacere di riproporre i tre modelli più significativi: il fucile da **Fanteria** (S.905), la carabina da **Cavalleria** (S.900) e il fucile da **Ufficiale** (S.910), dotato di stecher, e completato da tacca di mira e diottra regolabile in verticale e orizzontale. Tutti i modelli sono perfettamente fedeli agli originali e rappresentano un intreccio di tradizione armiera, arte e alta tecnologia. Le versioni Deluxe (L) ed Extra Deluxe (LL) sono caratterizzate da ricche incisioni. Nella versione Extra Deluxe, impreziosita da rimessi in oro sulla cartella, l'incisione è eseguita anche sulla fascetta di tenuta canna.

SPRINGFIELD TRAPDOOR

(1873-1885)

Carbine

Mod. S.900 - Standard
Mod. L.900 - Deluxe
Mod. LL.900 - Extra Deluxe

Rifle

Mod. S.905 - Standard
Mod. L.905 - Deluxe
Mod. LL.905 - Extra Deluxe

Officer

Mod. S.910 - Standard
Mod. L.910 - Deluxe
Mod. LL.910 - Extra Deluxe

At the end of the Civil War (1865), the war department had to replace the excellent muzzle loading muskets with metallic cartridge rifles. Between 1865 and 1866 appeared the first transformation of a muzzle loading Springfield musket made by Allin and in 1868 the first "Trapdoor Rifle" was built, further modified in 1870; three years later a new rifle in the .45-70 caliber answered to all the exigencies. During the following 20 years quite a big number of Springfield

Trapdoor rifles have been manufactured, among them also many versions with smooth barrel for cadets, for the target shooting and destined to the Officers. The Springfield Trapdoor rifle is a typical gun of the American soldiers, including General Custer. It equipped the troops also during the Spanish-American War (1898-1899). Davide Pedersoli Co. is pleased to be able to offer flawless reproductions of the three most significant models: the U.S. Army Rifle (S.905), the U.S. Cavalry Carbine (S.900) and the Officer's Rifle (S.910), this last equipped with a single set trigger, rear sight and Creedmoor sight adjustable in elevation and windage. All of these follow the originals perfectly and blend traditional gunsmith's handcraft arts to state of the art technology. The Deluxe (L) and Extra Deluxe (LL) versions are characterized by rich engravings. The Extra Deluxe version, more precious for the gold inlays on the frame, the engraving is made also on the stock's bands.



Deluxe model

Extra Deluxe model

S.905

S.910

S.900

USA 129

S.906
SPRINGFIELD TRAPDOOR
LONG RANGE RIFLE

Mod. S.906

Prodotto appositamente per il tiro a lunga distanza, è provvisto di impugnatura a pistola zigrinata che garantisce una migliore stabilità ed è completato con diottra e mirino a tunnel.

SPRINGFIELD TRAPDOOR
LONG RANGE RIFLE

Mod. S.906

Expressly produced for the long distance shooting, it is equipped with a detachable wood pistol grip, checkered, for a better shooting stability performance. It is completed with creedmoor and tunnel front sight with interchangeable inserts.

USA 129
IMPUGNATURA A PISTOLA

USA 129

Impugnatura a pistola applicabile a tutti i modelli Springfield Trapdoor.

DETACHABLE PISTOL GRIP

USA 129

Detachable wood pistol to fit all Springfield Trapdoor models.

Mod.	Cal.	Righe Grooves	Passo Twist		Lungh. canna Barrel length		Lungh. totale Overall length		Peso Weight		Stecher Set trigger	Diottra Creedmoor	Mirino a tunnel Tunnel sight
			mm	- inches	mm	- inches	mm	- inches	kg	- lbs			
S./L./LL.900	.45-70	3	560	- 1:22	558	- 22	1.049	- 41 ³ / ₁₆	3,300	- 7.27	-	-	-
S./L./LL.905	.45-70	3	560	- 1:22	828	- 32 ⁵ / ₁₆	1.318	- 51 ¹ / ₁₆	4,000	- 8.81	-	-	-
S.906	.45-70	6	460	- 1:18	828	- 32 ⁵ / ₁₆	1.318	- 51 ¹ / ₁₆	4,200	- 9.25	USA 430	USA 455	-
S./L./LL.910	.45-70	6	460	- 1:18	660	- 26	1.150	- 45 ⁵ / ₁₆	3,500	- 7.71	•	•	-





← 112 mm →

S.410
Kentucky / Pennsylvania
Navy Moll / Continental

S.434 - Cub Dixie / Pennsylvania Dixie
S.424 - Country Hunter
S.404 - Charles Moore Target



← 112 mm →

S.414
Alamo



← 116 mm →

S.480
Queen Anne



← 117 mm →

S.420
Harper's Ferry



← 144 mm →

S.400
Frontier



← 119 mm →

S.470
Le Page®



← 108 mm →

S.408
Mortimer pistol



← 123 mm →

S.438
Mortimer rifle



← 136 mm →

S.402
Jäger Hunter

S.416 - Jäger Target



← 143 mm →

S.468
Swiss Match

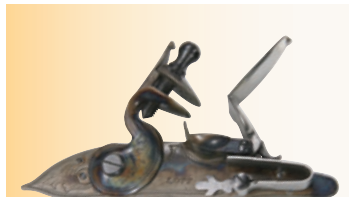

← 156 mm →

S.430
Lott for Indian Trade Musket



← 170 mm →

S.450
Brown Bess (Grice)



← 160 mm →

S.446
1777 Revolutionnaire

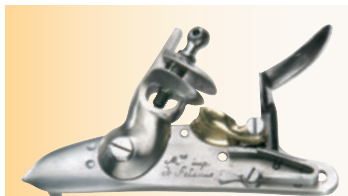

← 160 mm →

S.448
1777 Corrigè An IX
"An IX" Dragoons

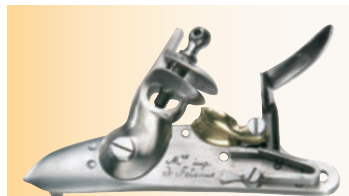

← 130 mm →

S.436
"An IX" / "An XIII" pistols

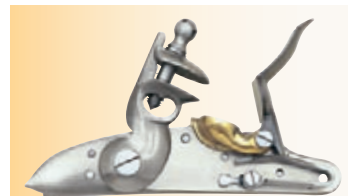

← 160 mm →

S.461
1798 Austrian



← 160 mm →

S.462
1763 Légère (1766) Charleville

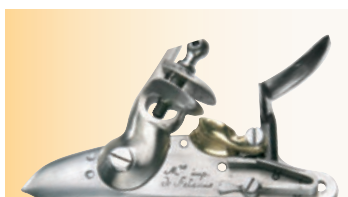

← 144 mm →

S.464
Ussaro Mod. 1786
An IX De Cavallerie

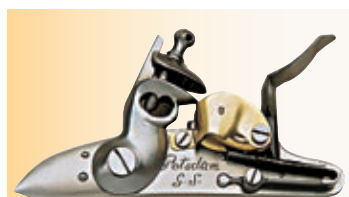

← 160 mm →

S.452
1809 Prussian



← 160 mm →

S.432
1795 Springfield



← 160 mm →

S.422
1816 Harper's Ferry



← 112 mm →

S.413
Kentucky / Pennsylvania
Navy Moll / Continental

S.435 - Cub Dixie / Pennsylvania Dixie
S.423 - Country Hunter
S.403 - Charles Moore Target

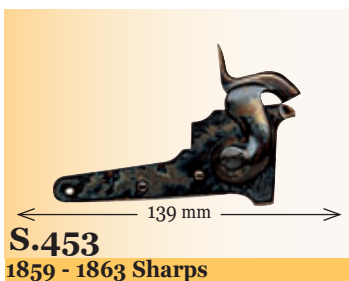
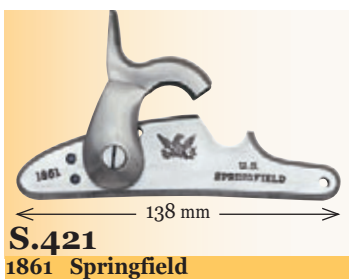
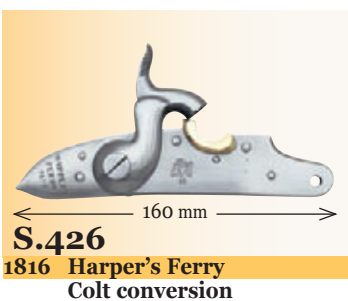
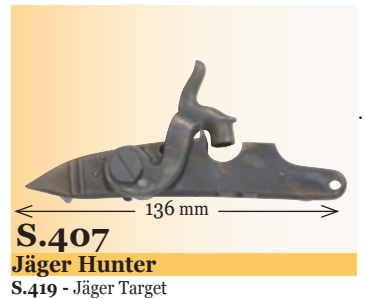
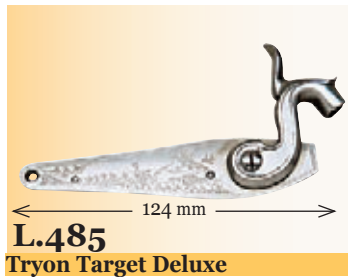
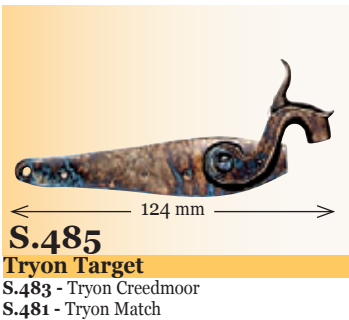
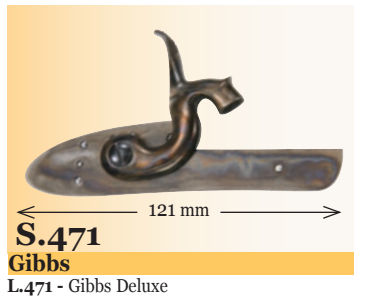
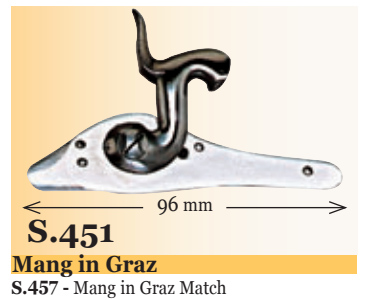
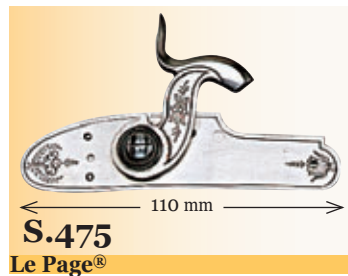
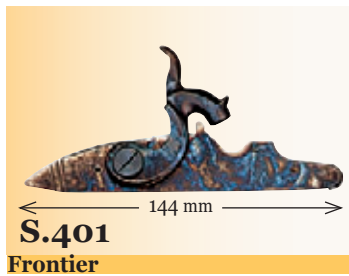



DP 518
Zouave

.58 cal. (Ottone / Brass)



DP 545
Texas

.50 cal. + tubetti per .44 e 58 cal.
+ spouts for .44 - .58 cal. (Rame / Copper)



DP 514
Walker

Regolabile / Adjustable (Ottone / Brass)



DP 523
Colt Pattern

.36 or .44 cal. (Rame / Copper)



DP 520
Colt Pattern

Regolabile / Adjustable (Rame / Copper)



DP 511
Club

.36 or .44 cal. (Rame / Copper)



DP 2000
"Pedersoli"

.36 or .44 cal. (Rame / Copper)



DP 555
Ape Basket Weave

.44 cal. (Ottone / Brass)



DP 575
French

.44 cal. (Rame / Copper)



DP 550
Florentin Nettuno

.50 cal. (Ottone / Brass)



DP 529
Remington Pattern

.36 or .44 cal. (Rame / Copper)



DP 537
Philadelphia

.31 cal. (Rame / Copper)



DP 535
Baby

.31 cal. (Rame / Copper)



DP 540
Unum

.31 cal. (Rame / Copper)



DP 539
Philadelphia

.31 cal. (ricoperta in pelle / leather covered)



DP 528
Alabama

.36 or .44 cal. (ricoperta in pelle / leather covered)



DP 533 **DP 526**
Tubular Deluxe **Tubular**

DP 533 - Con valvola / With valve.
(Ottone / Brass)
DP 526 - .44 cal. (Ottone / Brass)



DP 532 **DP 534**
Tubular **Tubular "Short"**

DP 532 - Regolabile / Adjustable.
(Ottone / Brass)
DP 534 - .44 cal. (Ottone / Brass)



DP 530
Paterson

Con cinque tubetti regolabili.
With five adjustable chargers.
(Ottone / Brass)



DP 547
Paterson

Regolabile / Adjustable (Ottone / Brass)



DP 565
Corno / Big powder horn

Corno grande porta polvere con cinghia.
Big powder horn with shoulder strap. 72 grs.



DP 566
Corno / Flat powder horn

Corno piccolo porta polvere.
Flat powder horn. 72 grs.



DP 564
English

Fiaschetta porta piombo in pelle rigida.
Shot pouch of hard leather.



DP 561
Irish

Fiaschetta porta piombo in pelle rigida.
Shot pouch of hard leather.



DP 560
Irish

Fiaschetta porta piombo in pelle morbida.
Shot pouch of soft leather.



DP 562
English

Fiaschetta porta piombo in pelle morbida.
Shot pouch of soft leather.



D. 645

Portafiaschetta in pelle con passante per l'applicazione alla cintura. (La fiaschetta non è inclusa)
Leather flask's holder that can be fastened at the belt. (Flask not included)



Fiaschetta a tracolla English / Fiaschetta a tracolla Irish - Shot shoulder pouch English / Shot shoulder pouch Irish

DP 563 ENGLISH - Fiaschetta in pelle, porta pallini con doppio dosatore. *Leather shot "snake" flask with double brass charger.*

DP 567 - IRISH - Fiaschetta in pelle, porta pallini con doppio dosatore. *Leather shot "snake" flask with double brass charger.*



DP 581 **DP 582**
Dosatore IRISH / ENGLISH

IRISH / ENGLISH shot measuring
Utilissimo per chi desidera realizzare una fiaschetta portapallini.
Can be used to make a shot dispensing flask.



USA 558

Imbuto in ottone, per caricamento fiaschetta.
Brass funnel for powder flask loading.

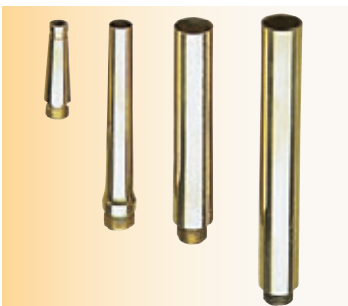

Code	disponibili in grani (grs) / grains availables
USA 210	15-18-21-24-30-36-45-48
USA 220	54-60-66-72
USA 225	84-100-120
Specificare grani - Specify grains	
USA 215	Set sei tubetti / Set of six spouts: 18/21/30/48/72/84 grs
USA 216	Set cinque tubetti / Set of five spouts: 36/45/60/72/100 grs

USA 210 - USA 220 - USA 225 - USA 215 - USA 216
Tubetti intercambiabili per fiaschetta / Spouts interchangeables for powder flask



USA 559

Imbuto in ottone, per fiaschetta Baby, Unum e Philadelphia e per Match set.
Brass funnel for Baby, Unum and Philadelphia powder flasks and for Match set.



Di altissima precisione, sono regolabili in verticale e con doppia regolazione orizzontale alla base e sull'oculare, per una esatta collimazione. È inoltre possibile una limitata regolazione della inclinazione rispetto all'asse dell'arma.

Interasse tra i fori delle viti di fissaggio: da 56 a 58,2 mm.

High precision Creedmoor sights adjustable for elevation and with double adjustment for windage at the base and on the eyepiece for an exact setting. Adjustable for different tang angles.

Distance between the two mounting holes: 2³/₁₆" up to 2⁵/₁₆" (56 up to 58,2 mm).

USA 431 - Silhouette Long Range
Con escursione in verticale di 76 mm (3").
With 3" (76 mm) vertical elevation.

USA 461 - Silhouette Middle Range
Con escursione in verticale di 50,8 mm (2").
With 2" (50,8 mm) vertical elevation.

USA 431-USA 461

Diottre Silhouette / Silhouette Creedmoor sights



Regolabili in verticale e in orizzontale sull'oculare. È inoltre possibile una limitata regolazione della inclinazione rispetto all'asse dell'arma. Ideale per il tiro alle medie e lunghe distanze sia con armi ad avancarica sia a retrocarica.

Interasse tra i fori delle viti di fissaggio da 56 a 58,2 mm.

Tang sight adjustable in elevation and windage adjustment on the eye piece. It is perfect for long distance target shooting both with muzzle loading and breech loading rifles.

Distance between the two mounting holes: 2³/₁₆" up to 2⁵/₁₆" (56 up to 58,2 mm).

USA 430 - Universal Long Range
Con escursione in verticale di 76 mm (3").
With 3" (76 mm) elevation.

USA 465 - Universal Middle Range
Con escursione in verticale di 50,8 mm (2").
With 2" (50,8 mm) elevation.

USA 430 - USA 465

Diottre Universal / Universal Creedmoor sights



Di altissima precisione, con regolazione micrometrica in verticale. La regolazione in orizzontale si ottiene ruotando i tamburi posti alla base. Una rotazione completa modifica il punto di impatto della palla di ca. 2,5 minuti d'angolo (in incremento di 1/2 minuto). Questo sistema consente una veloce e precisa regolazione.

Interasse tra i fori delle viti di fissaggio: da 56 a 58,2 mm.

The Soule tang sight is the world-wide choice of both target shooters and hunters.

High precision Creedmoor sights adjustable for elevation. One full turn of the windage knob changes the left or right aim point by 2,5 minutes of angle (in 1/2 minute increments). Quick and accurate return to center or previous setting is another big advantage. Ample windage movement for any shooting conditions.

Distance between the two mounting holes: 2³/₁₆" up to 2⁵/₁₆" (56 up to 58,2 mm).

USA 404 - Soule Middle Range
Con escursione in verticale di 50,8 mm (2").
With 2" (50,8 mm) elevation.

USA 405 - Soule XL Middle Range
Con escursione in verticale di 76 mm (3").
With 3" (76 mm) elevation.

USA 406 - Soule Long Range
Con escursione in verticale di 101,6 mm (4").
With 4" (101,6 mm) elevation.

USA 404 - USA 405 - USA 406

Diottre Soule / Soule Creedmoor sights

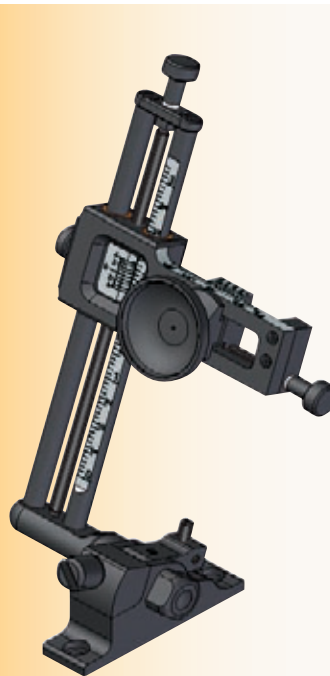

Diottra di altissima precisione con montanti cilindrici e decentrati rispetto all'asse della canna del fucile. Grazie alla sua posizione "a bandiera", la slitta porta oculare può disporre di una ampia regolazione orizzontale, con una escursione di 32 mm (1,26") particolarmente utile nelle situazioni in cui il campo di tiro è attraversato da venti di forte intensità.

La regolazione verticale può fruire di una escursione di 100 mm (3,94"). L'impostazione strutturale della diottra Goodwin consente inoltre di potere accedere alla camera di cartuccia con qualsiasi attrezzo necessario alla pulizia e al controllo della canna dell'arma tra uno sparo e l'altro.

Sulla base della diottra sono presenti due viti destinate alla individuazione della corretta posizione rispetto all'occhio del tiratore e a un solido bloccaggio dello strumento durante lo sparo. Interasse tra i fori per le viti di fissaggio: da 56 a 58,2 mm.

This high precision Creedmoor sight with cylindrical staff off center to the axis of the barrel was popular with long range target shooters in the late 1800's. Thanks to its "flag" position, the eye piece slide enables a very wide windage adjustment with a movement of 1.26" (32 mm), particularly useful in strong wind conditions. The elevation adjustment has a movement of 3.94" (100 mm). The structural features of the Goodwin Creedmoor sight offers the advantage to reach the rifle chamber with any cleaning device and to inspect the barrel between the shots. The sight base has a "tilt" screw which allows the staff to be set perfectly vertical at all elevations. Distance between the two mounting holes: 2³/₁₆" up to 2⁵/₁₆" (56 up to 58,2 mm).

USA 407

Diottra "Goodwin Style" / "Goodwin Style" Creedmoor



Set professionali in cofanetto legno / Professional sights set with wooden case

Code	Model	Composto da: / Including
USA 170	Soule XL Middle Range	USA 405 - USA 457 - USA 463 - USA 401
USA 171	Silhouette Long Range	USA 431 - USA 457 - USA 463 - USA 401
USA 172	Silhouette Middle Range	USA 461 - USA 457 - USA 463 - USA 401
USA 173	Universal Long Range	USA 430 - USA 469-R - USA 402
USA 174	Universal Middle Range	USA 465 - USA 469-R - USA 402
USA 175	Soule Long Range	USA 406 - USA 457 - USA 463 - USA 401
USA 176	Soule Middle Range	USA 404 - USA 457 - USA 463 - USA 401



USA 446
Diottra English / English Creedmoor sight

Di altissima precisione, è regolabile in verticale con circa 76 mm (3") di escursione e in orizzontale. La regolazione della perpendicolarità rispetto all'asse della canna la rende molto versatile e adattabile a svariati modelli di armi.
Interasse tra i fori delle viti di fissaggio: 45,30 mm.

*High accuracy, it is adjustable for 3" (76,2 mm) in elevation and it has windage adjustment. The perpendicular adjustment to the barrel's axis, makes it suitable to various guns.
Distance between the two mounting holes: 1 3/4" (45,30 mm).*



USA 468
Diottra Target / Target Creedmoor sight

Regolabile in verticale e orizzontale mediante lo scorrimento dell'oculare, con codolo a sezione tonda, completa di supporto per il fissaggio.

*Adjustable tang sight with rounded base, complete with mounting support.
To the elevation, determined by the fixing screw at the base, it adds the possibility of a further elevating adjustment by the eye piece sliding.*



USA 463
Oculare Professionale / Professional "Hadley style" Eye Piece

Oculare Professionale intercambiabile sulle diottrre USA 430, 431, 461, 465, 404, 405, 406, 407 e 446. Sul disco rotante presenta otto fori visori di diverso diametro (0,3 / 0,5 / 0,8 / 1 / 1,3 / 1,6 / 2 / 2,2 mm) da selezionare, senza smontare o allentare l'oculare, a sua volta provvisto di anello di gomma per attutire il contraccolpo dell'arma.

*It is interchangeable on the Creedmoor sights USA 430, 431, 461, 465, 404, 405, 406, 407 and 446, having 8 viewing holes of different diameters: (.012/.020/.031/.039/.051/.063/.078/.086" - 0,3 / 0,5 / 0,8 / 1 / 1,3 / 1,6 / 2 / 2,2 mm) placed on a rotating disk, which can be selected without disassembling or loosening the eye piece, following the available light.
The eye piece has a rubber ring to avoid any inconveniences due to recoil.*



USA 442

Diottra regolabile in orizzontale e in verticale, mediante lo scorrimento dell'oculare, con codolo a sezione quadra, completa di supporto per il fissaggio.

Creedmoor sight adjustable for windage and elevation, squared base, complete with mounting support.



USA 464
Diottra Lever Action / Lever Action Creedmoor sight

Regolabile in verticale e orizzontale. Sulla base è ricavata una foratura che la rende universale, con un interasse tra i fori delle viti di fissaggio da 47,7 a 57,4 mm, e consente di montarla su diversi modelli di armi.

Adjustable tang sight in elevation and windage. On the base there are holes which makes it universal with the distance between the holes of 1 7/8" up to 2 1/4" (47,7 up to 57,4 mm) and can be mounted on different rifles models.



USA 443

Diottra regolabile in orizzontale, mediante lo scorrimento dell'oculare, e in verticale, con codolo a sezione tonda, completa di supporto per il fissaggio.

Creedmoor sight adjustable for windage and elevation, rounded base, complete with mounting support.



USA 445

Diottra corta regolabile in verticale e in orizzontale mediante una breve escursione dell'oculare.
Interasse tra i fori delle viti di fissaggio: da 37,7 a 39,6 mm.

*Short Creedmoor sight adjustable for elevation and with a little windage adjustment in the eye piece.
Distance between the two mounting holes: 1 7/16" up to 1 9/16" (37,7 up to 39,6 mm).*



USA 436

Diottra lunga regolabile in verticale e in orizzontale mediante una breve escursione dell'oculare.
Interasse tra i fori delle viti di fissaggio: da 37,7 a 39,6 mm.

*Long Creedmoor sight adjustable for elevation and with a little windage adjustment in the eye piece.
Distance between the two mounting holes: 1 7/16" up to 1 9/16" (37,7 up to 39,6 mm).*



USA 433

Diottra corta regolabile in verticale e in orizzontale mediante una breve escursione dell'oculare.
Interasse tra i fori delle viti di fissaggio: da 37,7 a 39,6 mm.

*Short Creedmoor sight adjustable for elevation and with a little windage adjustment in the eye piece.
Distance between the two holes: 1 7/16" up to 1 9/16" (37,7 up to 39,6 mm).*



USA 454

Diottra regolabile in verticale e in orizzontale mediante una breve escursione dell'oculare.
Interasse tra i fori delle viti di fissaggio: da 37,7 a 54,4 mm.

*Creedmoor sight adjustable for elevation and with a little windage adjustment in the eye piece.
Distance between the two holes: 1 7/16" up to 2" (37,7 up to 54,4 mm).*



USA 444-455

USA 455 - Mirino a tunnel completo di dodici inserti intercambiabili (USA 425) per armi a retrocarica.
USA 455 - Tunnel sight with twelve interchangeable inserts (USA 425).
A = 9,5 mm (3/8") - $\alpha = 30^\circ$ - H = 8,9 mm (.350").

USA 444 - Mirino a tunnel completo di diciotto inserti intercambiabili (USA 424) per armi ad avancarica.
USA 444 - Tunnel sight with eighteen interchangeable inserts (USA 424).
A = 9,5 mm (3/8") - $\alpha = 30^\circ$ - H = 8,9 mm (.350").



USA 426-426A

USA 426 - Mirino a tunnel regolabile in orizzontale con vite micrometrica, completo di dodici inserti intercambiabili (USA 425). Dotato di dispositivo per la verifica del parallelismo.
USA 426 - Spirit level tunnel sight with micrometer adjustment for windage equipped with twelve interchangeable inserts (USA 425).
A = 9,5 mm (3/8") - $\alpha = 30^\circ$ - H = 12,5 mm (.492").

USA 426-A - Con le medesime caratteristiche del modello USA 426 ma completo di diciotto inserti intercambiabili (USA 424).
USA 426-A - Spirit level tunnel sight with micrometer adjustment for windage equipped with eighteen interchangeable inserts (USA 424).
A = 9,5 mm (3/8") - $\alpha = 30^\circ$ - H = 12,5 mm (.492").



USA 462-467

USA 462 - Mirino a tunnel con dispositivo per la verifica del parallelismo. È completo di dodici inserti intercambiabili (USA 425).
A = 9,5 mm - $\alpha = 30^\circ$ - H = 11 mm.

USA 462 - Tunnel sight with spirit level to check parallelism. It is completed with twelve interchangeable inserts (USA 425).
A = 3/8" (9,5 mm) - $\alpha = 30^\circ$ - H = .433" (11 mm).

USA 467 - Mirino a tunnel con dispositivo per la verifica del parallelismo è completo di diciotto inserti intercambiabili (USA 424).
A = 9,5 mm - $\alpha = 30^\circ$ - H = 11 mm.

USA 467 - Tunnel sight with spirit level to check the parallelism. It is completed with eighteen interchangeable inserts (USA 424).
A = 3/8" (9,5 mm) - $\alpha = 30^\circ$ - H = .433" (11 mm).



USA 469-A - 469-R

USA 469-A - Mirino a tunnel con diciotto inserti intercambiabili (USA 424).
A = 9,5 mm - $\alpha = 30^\circ$ - H = 11 mm.

USA 469-A - Tunnel sight with eighteen interchangeable inserts (USA 424).
A = 3/8" (9,5 mm) - $\alpha = 30^\circ$ - H = .433" (11 mm).

USA 469-R - Mirino a tunnel con dodici inserti intercambiabili (USA 425).
A = 9,5 mm - $\alpha = 30^\circ$ - H = 11 mm.

USA 469-R - Tunnel sight with twelve interchangeable inserts (USA 425).
A = 3/8" (9,5 mm) - $\alpha = 30^\circ$ - H = .433" (11 mm).



USA 457

Mirino a tunnel regolabile in orizzontale con vite micrometrica, completo di quindici inserti intercambiabili (USA 408). Dotato di dispositivo per la verifica del parallelismo.
A = 9,5 mm - $\alpha = 30^\circ$ - H = 17,5 mm.

Tunnel front sight windage adjustment with a micrometric screw, equipped with spirit level and fifteen interchangeable inserts (USA 408).
A = 3/8" (9,5 mm) - $\alpha = 30^\circ$ - H = .689 (17,5 mm).



USA 402

USA 402: Inserto con bolla per la verifica del parallelismo dell'arma.
A = 9,5 mm - $\alpha = 30^\circ$

USA 402A: *A = 12,5 mm - $\alpha = 30^\circ$.*

USA 402: Bubble (spirit level) insert replaces the rear sight when a tang sight is used. Prevents "canting" the rifle and promotes long range accuracy.
A = 3/8" (9,5 mm) - $\alpha = 30^\circ$.

USA 402A: *A = 1/2" (12,5 mm) - $\alpha = 30^\circ$.*

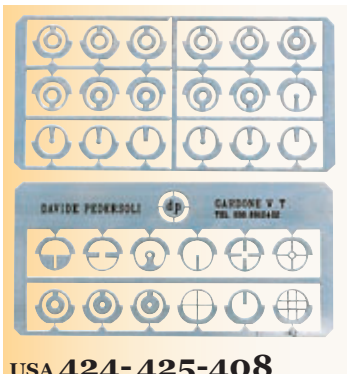

USA 424-425-408

USA 424: Set diciotto inserti intercambiabili per mirino a tunnel, ideale per armi ad avancarica.
USA 424: Eighteen tunnel sight inserts set for muzzle loading guns.

USA 425: Set dodici inserti intercambiabili per mirino a tunnel, ideale per armi a retrocarica.
USA 425: Twelve tunnel sight inserts set for cartridge firearms.

USA 408: Set quindici inserti intercambiabili universali per mirino a tunnel, di diverso diametro (dall'alto a sinistra: 2- 2,5 - 1,5 / 2,8 - 3 - 3,1 - 4 - 4,2 - 4,3 / 3,2 - 3,3 - 3,4 - 4,4 - 4,5 - 4,6 mm).
USA 408: Fifteen tunnel sight universal inserts set, different diameters, from top, left: .079 - .098 - .059 / .110 - .118 - .122 - .157 - .165 - .169 / .126 - .130 - .134 - .173 - .177 - .181" (2 - 2,5 - 1,5 / 2,8 - 3 - 3,1 - 4 - 4,2 - 4,3 / 3,2 - 3,3 - 3,4 - 4,4 - 4,5 - 4,6 mm).



USA 451

Mirino a tunnel mod. Svizzero.
A = 9,5 mm - $\alpha = 30^\circ$.
Integral headed tunnel front sight.
A = 3/8" (9,5 mm) - $\alpha = 30^\circ$



USA 401

Set sei bolle colorate (verde chiaro, rosso, azzurro) intercambiabili su mirino USA 426, 462, 467, e 457, secondo le diverse condizioni di luce.
Six interchangeable glass bubbles (spirit level) set with different colours to suit light conditions. These fit front tunnel sights USA 426, 457, 462 and 467. Colours are: light green, red and light blue.



USA 474

Mirino ribaltabile, utilizzabile sia come mirino a lama sia come mirino ad anello, per il tiro alle lunghe distanze.
A = 9,5 mm - $\alpha = 30^\circ$ - H = 11,4 mm

Folding front sight usable as globe sight for long distances shooting or as blade.
A = 3/8" (9,5 mm) - $\alpha = 30^\circ$ - H = .448" (11,40 mm).



USA 466 - USA 466T

Cannocchiale Malcolm 6X / Malcolm scope 6X

USA 466-R - Long Range
USA 466-T - Target
USA 466 - Hunting

Riproduzione del cannocchiale di mira, in acciaio brunito, prodotto dalla "Wm Malcolm Rifle Telescope" di Syracuse, New York, nella seconda metà dell'Ottocento e distribuito in Europa in esclusiva dalla Davide Pedersoli.

Lo strumento, dotato di 6 ingrandimenti, ha un diametro di 19 mm (3/4") e, con prolunga da 5", è lungo 864 mm (34"), ideale per canne da 28" a 32".

Completo di attacchi, di una base per attenuare l'azione del rinculo e di un anello di contrasto per il corpo tubolare è disponibile nel modello **Hunting** e nel modello **Target** corredato inoltre dal cursore per la regolazione micrometrica in verticale.

Il modello **Long Range** dispone di un attacco

posteriore con regolazione micrometrica in verticale e in orizzontale, di altissima precisione. La base di fissaggio con slitta longitudinale permette lo smontaggio del cannocchiale senza modificarne la regolazione già impostata. A richiesta sono disponibili i tubi di prolunga da 7" (USA 237-07) e da 9" (USA 237-09), per canne da 34" o più.

USA 508

Cannocchiale Malcolm 3X - Short

Cannocchiale di mira a 3 ingrandimenti, ideale per il tiro alle medie distanze.

Un ottica di seconda generazione che è stata utilizzata anche durante il secondo conflitto mondiale.

Con un sistema di attacco molto pratico, offre la possibilità di regolazioni in verticale e in orizzontale. Lunghezza: 432 mm (17").

USA 466-R - Long Range
USA 466-T - Target
USA 466 - Hunting

The reproduction of scope, made in blued steel, formerly produced by "Wm Malcolm Rifle Telescope" of Syracuse, New York in the second half of the 1800's distributed exclusively in Europe by Davide Pedersoli.

The scope has a magnification of 6X, the 3/4" (19 mm) tube diameter is supplied with a 5" extension ideal for 28" to 32" barrels.

Equipped with mounts, a heavy duty base to handle heavy recoil and locking rings to prevent backwards movements, is available in the **Hunting** model and the **Target** model equipped also with special fine elevation adjustment scale.

The **Long Range** model has a high precision micrometric mount for elevation and windage. This mount allows the scope to be totally removed from the rifle then replaced without any changes to adjustment. Accessories which can be ordered: 7" extension (USA 237-07) and 9" extension (USA 237-09) for 34" barrels and longer.

USA 508 Malcolm scope 3X - Short model

The 3X short scope ideal for mid range target shooting. A second generation scope used also during WW-2.

With a very practical mount, having elevation and windage adjustments. Length: 17" (432 mm).

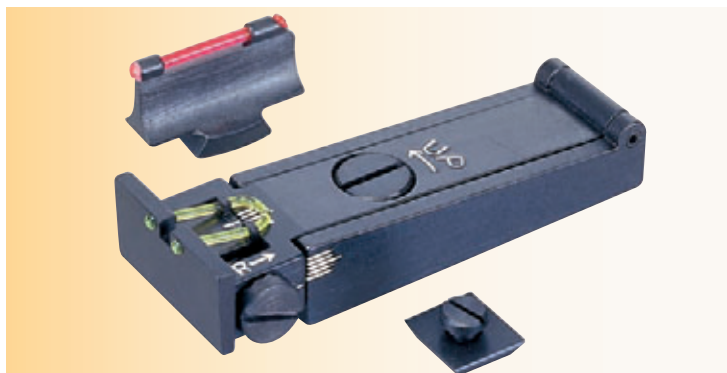

USA 411 - USA 412- USA409 - USA 410

Set mirino e tacca di mira in fibra ottica / Fiber optic front sight and rear sight set

Disponibile in diversi modelli, intercambiabili con quelli di serie. La tacca di mira è regolabile in verticale e in orizzontale, mediante apposite viti micrometriche.

USA 411 - Set mirino e tacca di mira per Kodiak Express ad avancarica e altri modelli

Mirino: da assemblare sulla rampa (esistente) - H 7 mm.

Tacca di mira: con base convessa per canne con bindella concava.

USA 412 - Set mirino e tacca di mira per Rolling Block ad avancarica e altri modelli

Mirino: con base concava per diametri da 18 a 23 mm - H 16,5 mm.

Tacca di mira: con base concava per canne tonde con diametri da 27 a 32 mm.

USA 409 - Set mirino e tacca di mira per fucili ad avancarica

Mirino: con base per coda di rondine di 9,5x30°x2,5 mm - H 12 mm.

Tacca di mira: con base per canne ottagonali da 20 a 24 mm e con tassello per coda di rondine di 9,5x30°x2,5 mm.

USA 410 - Set mirino e tacca di mira per fucili a retrocarica

Mirino: con base per coda di rondine di 9,5x30°x2,5 mm - H 12 mm.

Tacca di mira: con base per canne ottagonali da 24 a 28 mm e con tassello per coda di rondine di 9,5x30°x2,5 mm.

Fiber optic front sight and rear sight set
Available in various models, they are interchangeable with those already on the guns.

Rear sights are adjustable for elevation and windage, thanks to proper micrometer screws.

USA 411 - Front sight and rear sight set for muzzleloading Kodiak Express and other models

Front sight: to mount on the existing base - Height: .275 (7 mm).

Rear sight: convex base for barrels with concave rib.

USA 412 - Front sight and rear sight set for M.L. Rolling Block and other models

Front sight: with concave base for round barrels with diameter: .708÷.905 (18÷.23 mm). Height: .650 (16,5 mm).

Rear sight: with concave base for round barrels with diameter: 1.062÷1.259 (27÷.32 mm).

USA 409 - Front sight and rear sight set for muzzleloading rifles

Front sight: with dovetail base: 3/8"x30°xheight .0984 (9,5x30°xh.2,5 mm) - Height: .472 (12 mm).

Rear sight: with base for octagonal barrels with dimension: .787÷.944 (20÷24 mm) with dovetail base: 3/8"x30°xheight .0984 (9,5x30°xh.2,5 mm).

USA 410 - Front sight and rear sight set for breech loading rifles

Front sight: with dovetail base: 3/8"x30°xheight .0984 (9,5x30°xh.2,5 mm). - Height: .472 (12 mm).

Rear sight: with base for octagonal barrels with dimension: .944÷1.102 (24÷28 mm) with dovetail base: 3/8"x30°xheight .0984 (9,5x30°xh.2,5 mm).



USA 429 - Tacca di mira a rampa, regolabile in verticale.

Coda di rondine: 9,5 mm x 30°.

USA 429 - Ramp rear sight adjustable for elevation.

A = 3/8" (9,5 mm) - α = 30°.

USA 456 - Tacca di mira regolabile in verticale.

Coda di rondine: 9,5 mm x 30°.

USA 456 - Rear sight adjustable for elevation.

A = 3/8" (9,5 mm) - α = 30°.



USA 473

USA 473 - Tacca di mira per Springfield Trapdoor modello U.S. 1879, meglio conosciuta come modello "Buckhorn". Venne utilizzata a partire dal 1879 fino al 1884, quando fu introdotto il modello Buffington. È provvista di rampa graduata fino a 500 yards (457 metri) e di ritto alzo fino a 1500 yards (1.372 metri). Regolazione per derivazione.

USA 473 - U.S. model 1879 Springfield Trapdoor rear sight, sometimes referred to as "Buckhorn" style. Used on Trapdoor rifles from 1874 until superseded by Buffington style in 1884. Side ramps are graduated to 500 yards and the ladder to 1500 yards. Slide has windage adjustment.



USA 428

USA 428 - Tacca di mira a base piana, con due fogliette regolabili e abbattibili.

USA 428 - Rear sight, flat base, with two adjustable and folding leaves.

USA 428-A - Tacca di mira a base convessa, con due fogliette regolabili e abbattibili.

USA 428-A - Rear sight with convex base, with two adjustable and folding leaves.

Code Blocco Block	Cavità Cavity	Ø (inches)	Ø (mm)	Peso ca. est. Weight (grs)	Code Blocco Block	Cavità Cavity	Ø (inches)	Ø (mm)	Peso ca. est. Weight (grs)
PALLE TONDE - ROUND BALLS									
USA 307-308	2	.308	7,82	46	PALLE MAXI - MAXI BULLETS				
USA 307-310	2	.310	7,87	47	USA 308-333	1	.333	8,46	190
USA 307-315	2	.315	8,00	49	USA 308-454	1	.454	11,53	250
USA 307-320	2	.320	8,13	50	USA 308-504	1	.504	12,80	360
USA 307-323	2	.323	8,20	51	USA 308-540	1	.540	13,72	420
USA 307-330	2	.330	8,38	55	PALLE MINIE - MINIE BULLETS				
USA 307-345	2	.345	8,76	60	USA 304-350	1	.350	8,89	200
USA 307-354	2	.354	8,99	66	USA 304-400	1	.400	10,16	316
USA 307-362	2	.362	9,19	71	USA 304-447	1	.447	11,35	350
USA 307-375	2	.375	9,52	80	USA 309-450	1	.450	11,43	310
USA 307-390	2	.390	9,90	95	USA 302-547	1	.547	13,89	520
USA 307-395	2	.395	10,03	97	USA 309-577	1	.577	14,65	620
USA 307-400	2	.400	10,16	99	USA 309-580	1	.580	14,73	640
USA 307-410	2	.410	10,41	107	USA 309-585	1	.585	14,86	645
USA 307-424	2	.424	10,77	109	PALLE CONICHE PER AVANCARICA				
USA 307-430	2	.430	10,92	121	LONG BULLETS FOR MUZZELOADING				
USA 307-435	2	.435	11,05	123	USA 308-347	1	.347	8,81	200
USA 307-437	2	.437	11,10	124	USA 318-400	1	.400	10,16	310
USA 307-440	2	.440	11,18	131	USA 303-451	1	.451	11,45	485
USA 307-445	2	.445	11,30	133	USA 308-451	1	.451	11,45	520
USA 307-447	2	.447	11,35	134	USA 318-451	1	.451	11,45	500
USA 307-451	2	.451	11,45	136	USA 318-500	1	.500	12,68	450
USA 307-454	2	.454	11,53	139	PALLE CONICHE PER RETROCARICA				
USA 307-457	2	.457	11,61	142	CONICAL BULLETS FOR BREECH LOADING				
USA 307-462	2	.462	11,73	148	USA 303-458	1	.458 dia.	11,63	410
USA 307-464	2	.464	11,78	151	USA 312-458	1	.458 dia.	11,63	535
USA 307-490	2	.490	12,45	177	USA 303-459	1	.459 dia.	11,66	500
USA 307-498	2	.498	12,65	187	USA 303-512	1	.512 dia.	13,00	450
USA 307-504	2	.504	12,80	193	PALLE SPITZER - SPITZER BULLETS				
USA 307-531	2	.531	13,49	225	USA 311-459	1	.459 dia.	11,66	500
USA 307-535	2	.535	13,59	227	PALLE PER CARTUCCIA DI CARTA - PAPER CARTRIDGE BULLETS				
USA 306-562	1	.562	14,27	240	STILE MODERNO / MODERN DESIGN				
USA 306-575	1	.575	14,60	285	USA 317-458	1	.458	11,63	385
USA 306-614	1	.614	15,60	345	USA 317-541	1	.541	13,74	535
USA 306-675	1	.675	17,14	450	STILE ORIGINALE / ORIGINAL DESIGN				
USA 306-682	1	.682	17,32	470	USA 319-458	1	.458	11,63	385
USA 306-715	1	.715	18,16	545	USA 319-541	1	.541	13,74	535
USA 306-732	1	.732	18,59	585					

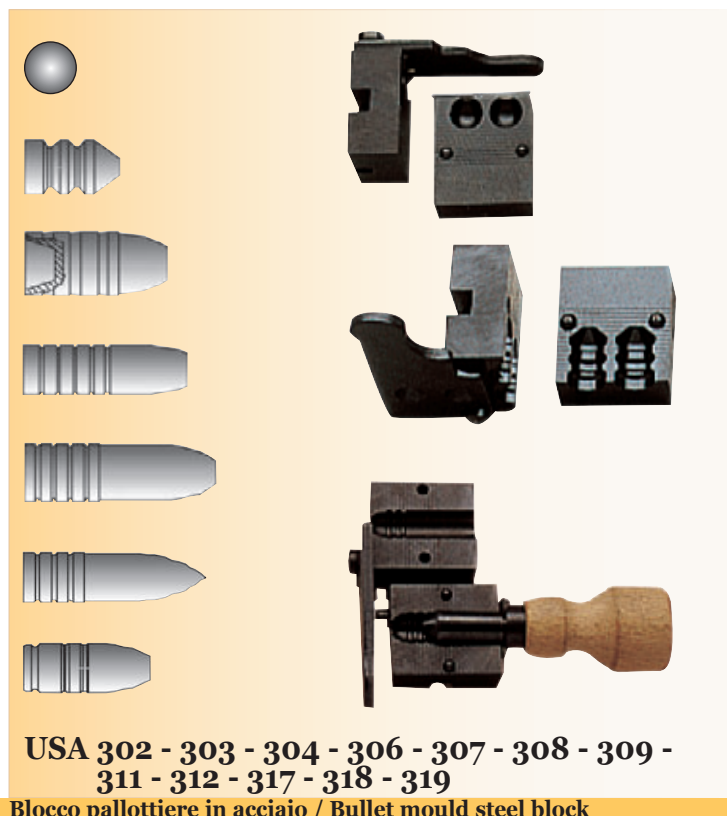

USA 302 - 303 - 304 - 306 - 307 - 308 - 309 - 311 - 312 - 317 - 318 - 319

Blocco pallottiere in acciaio / Bullet mould steel block



USA 316

Pinze con manici in legno per blocco pallottiere in acciaio.
Handles for bullet moulds steel block.



USA 292-298-293

Walker - Pocket - Army

In acciaio brunito

USA 292 - Walker

Per una palla ogivale cal. .44.

USA 293 - Army

Per una palla tonda e una ogivalecal. .36 o .44.

USA 298 - Pocket

Per una palla tonda e una ogivale cal. .31 o .36.

Blue finish steel

USA 292 - Walker

For one conical bullet .44 caliber.

USA 293 - Army

For one round ball and for one conical bullet

.36 or .44 caliber.

USA 298 - Pocket

For one round ball and for one conical bullet

.31 or .36 caliber.



USA 250
Colt Pattern

Per una palla tonda e una ogivale, cal. .31, .36 o .44.
For one round ball and for one conical bullet .31, .36 or .44 caliber.



USA 265
Kentucky

Per due palle tonde, cal. .31, .36, .44, .45, o .50.
For two round balls .31, .36, .44, .45 or .50 caliber.



USA 300
Brown Bess

Per una palla tonda cal. .75.
For one round ball .75 caliber.



USA 305
Walker

Per una palla ogivale cal. .44.
For one conical bullet .44 caliber.



USA 270
Remington Pattern

Per una palla tonda e una ogivale, cal. .36 o .44.
For one round ball and for one conical bullet .36 or .44 caliber.



USA 295
Zouave

Per una palla Minié cal. .58.
For one Minié bullet .58 caliber.



USA 301
1777 / An IX

Per una palla tonda cal. 17,5 mm (.69).
For one round ball 17,5 mm (.69) caliber.



USA 310
Paterson

Per una palla tonda cal. .36.
For one round ball .36 caliber.

Code	Ø (inches)	Ø (mm)	Peso Weight (grs)	Code	Ø (inches)	Ø (mm)	Peso Weight (grs)
PALLE TONDE - ROUND BALLS							
USA 520-307	.307	7,80	45	USA 522-504	.504	12,80	360
USA 520-314	.314	7,97	49	USA 522-540	.540	13,72	420
USA 520-323	.323	8,20	51	PALLE MINIE - MINIÉ BULLETS			
USA 520-330	.330	8,38	55	USA 523-400	.400	10,16	316
USA 520-345	.345	8,76	60	USA 523-447	.447	11,35	350
USA 520-350	.350	8,89	63	USA 523-450	.450	11,43	310
USA 520-354	.354	8,99	66	USA 523-547	.547	13,89	520
USA 520-362	.362	9,19	71	USA 523-577	.577	14,65	620
USA 520-373	.373	9,47	78	USA 523-580	.580	14,73	640
USA 520-375	.375	9,52	80	USA 523-585	.585	14,86	645
USA 520-395	.395	10,03	97	PALLE CONICHE PER AVANCARICA			
USA 520-411	.411	10,44	108	LONG BULLETS FOR MUZZLELOADING			
USA 520-430	.430	10,92	121	USA 526-347	.347	8,81	200
USA 520-435	.435	11,05	123	USA 526-400	.400	10,16	310
USA 520-437	.437	11,10	124	USA 526-451	.451	11,45	520
USA 520-440	.440	11,18	131	USA 529-451	.451	11,45	500 flat n.
USA 520-445	.445	11,30	133	USA 521-451	.451	11,45	485
USA 520-447	.447	11,35	134	USA 521-500	.500	12,68	450
USA 520-451	.451	11,45	136	PALLE CONICHE PER RETROCARICA			
USA 520-454	.454	11,53	139	CONICAL BULLETS FOR BREECH LOADING			
USA 520-457	.457	11,61	142	USA 526-415	.415 dia.	10,54	420
USA 520-462	.462	11,73	148	USA 526-458	.458 dia.	11,63	410
USA 520-464	.464	11,78	151	USA 529-458	.458 dia.	11,63	535
USA 520-490	.490	12,45	177	USA 526-459	.459 dia.	11,66	500
USA 520-495	.495	12,57	184	USA 526-462	.462 dia.	11,73	590
USA 520-504	.504	12,80	193	USA 526-512	.512 dia.	13,00	450
USA 520-535	.535	13,59	227	PALLE SPITZER			
USA 520-541	.541	13,74	235	SPITZER BULLETS			
USA 520-575	.575	14,60	285	USA 528-459	.459 dia.	11,66	500
USA 520-614	.614	15,60	345	PALLE PER CARTUCCIA DI CARTA			
USA 520-675	.675	17,14	450	PAPER CARTRIDGE BULLETS			
USA 520-682	.682	17,32	470	STILE MODERNO / MODERN DESIGN			
USA 520-695	.695	17,65	500	USA 524-458	.458	11,63	385
USA 520-715	.715	18,16	545	USA 524-541	.541	13,74	535
USA 520-732	.732	18,59	585	STILE ORIGINALE / ORIGINAL DESIGN			
PALLE MAXI - MAXI BULLETS				USA 519-458	.458	11,63	385
USA 522-454	.454	11,53	250	USA 519-541	.541	13,74	535

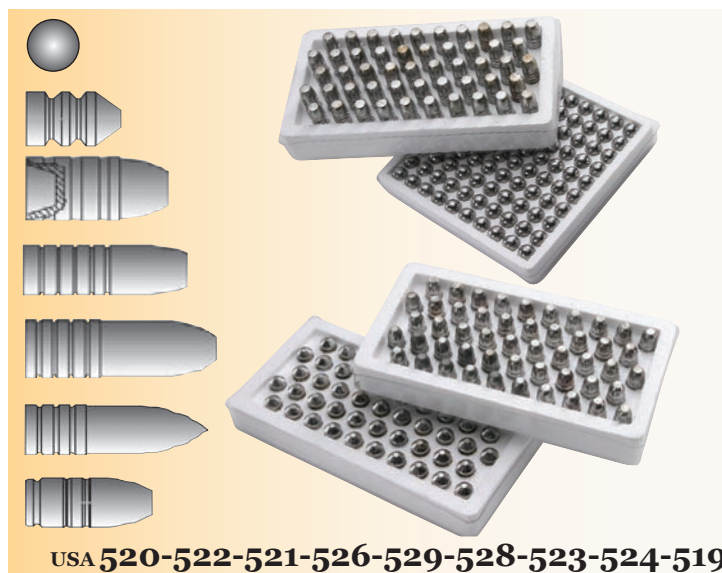

USA 520-522-521-526-529-528-523-524-519

- USA 520 - Confezione 100 palle tonde.
- USA 522 - Confezione 50 palle maxi.
- USA 521 - Confezione 50 palle coniche round nose.
- USA 526 - USA 529 - Confezione 50 palle coniche flat nose.
- USA 528 - Confezione 50 palle "spitzer style".
- USA 523 - Confezione 50 palle Minié.
- USA 524 - Confezione 50 palle (stile moderno) per cartuccia di carta.
- USA 519 - Confezione 50 palle (stile originale) per cartuccia di carta.
- USA 520 - 100 round balls box.
- USA 522 - 50 maxi bullets box.
- USA 521 - 50 long bullets box.
- USA 526 - USA 529 - 50 conical, flat nose bullets box.
- USA 528 - 50 "spitzer style" bullets box.
- USA 523 - 50 Minié bullets box.
- USA 524 - 50 "modern design" paper cartridge bullets box.
- USA 519 - 50 "original design" paper cartridge bullets box.

Palle / Balls & Bullets



USA 492
Ingrassatore / Bullet greaser

Indispensabile per l'operazione di ingrassaggio di palle coniche, maxi e Minié, è realizzato in acciaio sabbato e brunito.

Useful to simplify the greasing of long, maxi and Minié bullets. It is made of sanded and blued steel.

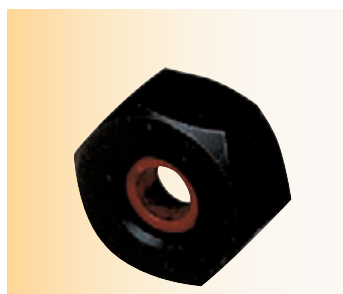

USA 495
Inserto ingrassatore / Bullet greaser insert

Inserto intercambiabile per ingrassatore.
Interchangeable insert for bullet greaser.

Code	Code	Ø (inches)	Ø (mm)
USA 492-400	USA 495-400	.400	10,16
USA 492-445	USA 495-445	.445	11,30
USA 492-450	USA 495-450	.450	11,43
USA 492-459	USA 495-459	.459	11,65
USA 492-500	USA 495-500	.500	12,70
USA 492-540	USA 495-540	.540	13,70
USA 492-547	USA 495-547	.547	13,90
USA 492-580	USA 495-580	.580	14,70

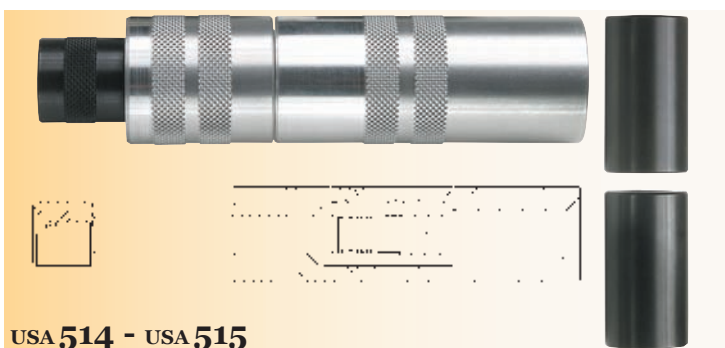

USA 514 - USA 515
Calibratore / Bullet sizer

Di facile utilizzo, è prodotto con corpo in alluminio e due matrici in acciaio aventi diversa misura. Il calcoio presenta una estremità piatta per le palle coniche e maxi (USA 514) e una conica per quelle Minié (USA 515).

Easy to use, it is made of aluminium with two steel dies having a different size. The punch has a flat head for the long and maxi bullets (USA 514), and a conical head for the Minié bullets (USA 515).

Code	Ø (inches)	Ø (mm)	Palla Bullet
USA 514-346	.346 / .345	8,79 / 8,77	maxi - long
USA 514-400	.400 / .399	10,16 / 10,14	maxi - long
USA 514-450	.450 / .449	11,43 / 11,41	maxi - long
USA 514-459	.459 / .458	11,65 / 11,63	maxi - long
USA 514-500	.500 / .499	12,70 / 12,68	maxi - long
USA 514-540	.540 / .538	13,70 / 13,68	maxi - long
USA 515-346	.346 / .345	8,79 / 8,77	Minié
USA 515-400	.400 / .399	10,16 / 10,14	Minié
USA 515-445	.445 / .444	11,30 / 11,28	Minié
USA 515-547	.547 / .546	13,90 / 13,88	Minié
USA 515-580	.580 / .578	14,70 / 14,68	Minié



USA 494
The Roller

Premesso che ogni fusione dello stesso pallottiere presenta delle piccole differenze dimensionali determinate dalla diversità di solidificazione del piombo, si rende necessario ridurre tali varianti al fine di migliorare la costanza dimensionale. Ciò è possibile con il nostro rullatore, che migliora anche la sfericità delle palle stesse, riducendo al minimo la materozza di fusione.

È prodotto in acciaio sabbato e brunito, con disco e interno rettificati. L'operazione di rullatura avviene manualmente, ruotando il disco inserito nel vano del rullatore, dove verrà disposto un numero sufficiente di palle dello stesso calibro.

Knowing that bullets cast from moulds will have small dimensional differences when they harden, it is necessary to reduce such variations to improve the dimensional constancy. This is possible with our roller, which improves also the roundness of the same balls, reducing to the minimum the casting head-head. It is produced with steel, sanded and blued, with rectified disk and inside. The rolling operation is made by hands, rolling the disk inserted into the roller-body, where a sufficient number of balls of the same caliber have been placed to cover the bottom.

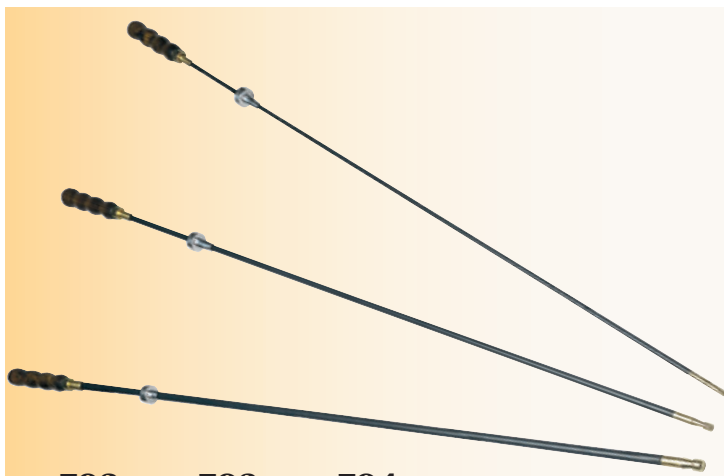

USA 702 - USA 703 - USA 704
Bacchetta in fibra per fucile / Fiberglass rod for rifle

Altamente resistente e flessibile è avvitata a una impugnatura di legno con un particolare sistema di inserimento che riduce notevolmente la possibilità di rottura della parte filettata. All'estremità opposta è assemblato un puntale in ottone con filetto maschio da 5MA (disponibile, a richiesta, la conversione 10-32 - USA 738) al quale possono essere applicati tutti i vari accessori per il caricamento e la pulizia dell'arma. La bacchetta, completa di salvabocca e portastraccio in ottone è disponibile nelle seguenti misure:

Highly resistant and flexible it is screwed to a wooden handle with a particular inlet system which considerably reduces break possibilities of the thread end. At the opposite end, assembled there is a brass jag (male) 5MA threaded (also available the conversion 10-32 - USA 738). To the jag you can assemble all various accessories for the loading and cleaning of the rifle. The rod, completed of a nylon muzzle protector and a brass jag, is available in the following sizes:

Code	Cal.	Ø (mm)	Lunghezza Length (mm)	Ø (inches)	Lunghezza Length (inches)
USA 702-31	.31/.32	7	1.000	.275	39 3/8
USA 702-36	.36	7	1.000	.275	39 3/8
USA 703-45	.44/.45	9	1.000	.354	39 3/8
USA 703-50	.50	9	1.000	.354	39 3/8
USA 703-54	.54	9	1.000	.354	39 3/8
USA 703-58	.58	9	1.000	.354	39 3/8
USA 704-69	.69	12	1.100	.472	43 5/16
USA 704-75	.75	12	1.100	.472	43 5/16

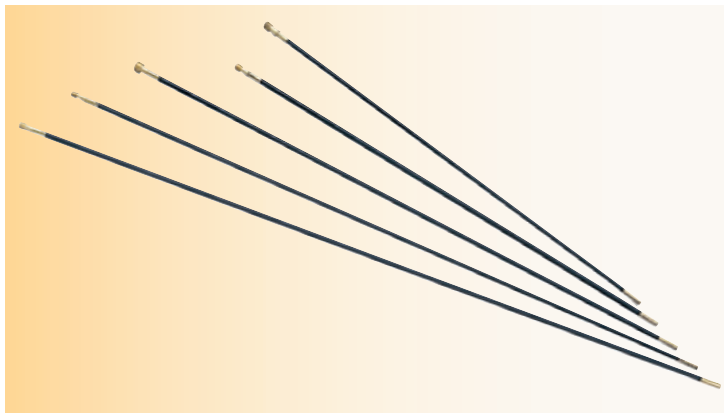

Perfettamente intercambiabile con quella in legno normalmente in dotazione con l'arma, è provvista di estremità in ottone, di cui una con filetto maschio, metrico e l'altra con filetto femmina, americano (5MA / 10-32), che consentono l'applicazione dei vari accessori per personalizzare la propria arma a seconda delle diverse esigenze. Per stabilire la bacchetta di cui necessitate, consultate la tabella che riporta i diametri, le lunghezze disponibili, e i codici corrispondenti. Tutte le bacchette possono essere destinate anche a calibri diversi da quelli indicati; in tal caso specificare il calibro desiderato.

They are perfectly interchangeable with those made of wood and they are equipped with brass ends, of which one (male) is threaded with metric system and one end (female) is threaded with the American system (5MA / 10-32), enabling the use of different accessories, following the exigencies of your gun. To look for the necessary ramrod, consult the list with diameters, lengths and the proper codes.

All the fiberglass ramrods can be equipped to suits other calibers than those mentioned in this list, simply specify the desiderate caliber.

Code	Ø (mm)	Lunghezza Length (mm)	Ø (inches)	Lunghezza Length (inches)	Esempi d'utilizzo For following and other models
USA 740-32	7	700	.275	27 9/16	Frontier carbine .32 cal.
USA 740-36	7	700	.275	27 9/16	Frontier carbine .36 cal.
USA 748-32	7	900	.275	35 7/16	Kentucky .32 cal.
USA 747-32	7	980	.275	38 5/8	Frontier .32 cal.
USA 747-36	7	980	.275	38 5/8	Frontier .36 cal.
USA 749-32	7	1.060	.275	41 3/4	Pennsylvania .32 cal.
USA 753-12	9	640	.354	25 1/4	Doppietta Slug - D/B Shotgun 12 ga.
USA 754-20	9	685	.354	27	Doppietta - D/B Shotgun 20 ga.
USA 760-45	9	695	.354	27 3/8	M.L.R. Block .45 cal.
USA 760-50	9	695	.354	27 3/8	M.L.R. Block .50 cal.
USA 740-45	9	700	.354	27 9/16	Frontier carbine .45 cal.
USA 740-50	9	700	.354	27 9/16	Frontier carbine .50 cal.
USA 746-12	9	710	.354	28	Doppietta - D/B Shotgun 12 ga.
USA 746-50	9	710	.354	28	Kodiak Express .50 cal.
USA 746-54	9	710	.354	28	Kodiak Express .54 cal.
USA 746-58	9	710	.354	28	Kodiak Express .58 cal.
USA 743-10	9	750	.354	29 9/16	Doppietta - D/B Shotgun 10 ga.
USA 744-12	9	790	.354	31 1/8	Mortimer perc. 12 ga.
USA 744-45	9	790	.354	31 1/8	Tryon Creedmoor/Mortimer .45 cal.
USA 755-45	9	830	.354	32 11/16	Tryon .45 cal.
USA 755-50	9	830	.354	32 11/16	Tryon .50 cal.
USA 755-54	9	830	.354	32 11/16	Tryon .54 cal.
USA 745-12	9	890	.354	35 1/16	Mortimer flint 12 ga.
USA 745-54	9	890	.354	35 1/16	Mortimer .54 cal.
USA 757-45	9	900	.354	35 7/16	Kentucky .45 cal.
USA 757-50	9	900	.354	35 7/16	Kentucky .50 cal.
USA 756-45	9	980	.354	38 5/8	Frontier .45 cal.
USA 756-50	9	980	.354	38 5/8	Frontier .50 cal.
USA 758-45	9	1.060	.354	41 3/4	Pennsylvania .45 cal.
USA 750-45	10	720	.394	28 3/8	Fucili / Rifles .45 cal.
USA 750-50	10	720	.394	28 3/8	Fucili / Rifles .50 cal.
USA 750-54	10	720	.394	28 3/8	Fucili / Rifles .54 cal.

Bacchetta in fibra per fucili ad avancarica / Fiberglass ramrod for muzzleloading guns



USA 752
Set bacchetta in fibra per fucili a retrocarica / Fiberglass rod set for breech loading rifle

Indispensabile per la pulizia delle armi a retrocarica, è composto da bacchetta in fibra con manico in legno, girabacchetta e portastraccio, completato da scovolo in lana e scovolo in bronzo, portastraccio con asola e venticinque straccetti per la pulizia.

Indispensable for the breech loading rifles cleaning, it is composed of a fiberglass rod with wood handle, rod swivel and jag, complete with wool brush and bronze brush, jag with slot and no. 25 cleaning patches.

Indispensable for the breech loading rifles cleaning, it is composed of a fiberglass rod with wood handle, rod swivel and jag, complete with wool brush and bronze brush, jag with slot and no. 25 cleaning patches.

Code	Cal.	Ø (mm)	Lunghezza Length (mm)	Ø (inches)	Lunghezza Length (inches)
USA 752-36	.36	8	900	.315	35 7/16
USA 752-45	.45	8	900	.315	35 7/16
USA 752-50	.50	8	900	.315	35 7/16



USA 349
Bacchetta in alluminio per fucile / Aluminium rod for rifle

Completa di impugnatura, puntale e salvabocca. Completed with handle, jag and muzzle protector.

Code	Ø (mm)	Lunghezza Length (mm)	Ø (inches)	Lunghezza Length (inches)
USA 349-07	7	1.000	.275	39 3/8
USA 349-09	9	1.000	.354	39 3/8

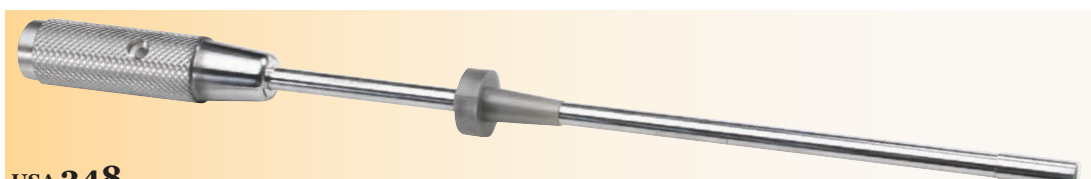

USA 348
Bacchetta in alluminio per pistola / Aluminium rod for pistol

Completa di impugnatura, puntale e salvabocca. Completed with handle, jag and muzzle protector.

Code	Ø (mm)	Lunghezza Length (mm)	Ø (inches)	Lunghezza Length (inches)
USA 348-07	7	320	.275	12 5/8
USA 348-09	9	320	.354	12 5/8



USA 706
Girabacchetta / Rod swivel

Accessorio in ottone, antifrizione, che permette la rotazione della bacchetta durante le fasi di caricamento e pulizia dell'arma, senza danneggiare la rigatura. Con due estremità filettate 7MA, è realizzato in modo da ridurre il rischio di eventuali rotture delle parti filettate. Può essere applicato a tutte le bacchette di caricamento.

Brass accessory anti-friction which enables the rotation of the rod during the loading and cleaning phases, without damaging the rifling twist. With two 7MA threaded ends, it is manufactured to reduce the risk of possible break of the threaded parts.



USA 751
Set per bacchetta / Fiberglass rod set

Set per bacchetta composto da impugnatura in legno, girabacchetta, riduzione in ottone maschio, con filetto metrico e filetto americano (5MA / 10-32) e riduzione in ottone femmina con filetto metrico e filetto americano (7MA / 10-32), per consentire l'applicazione di diversi tipi di accessori.

Fiberglass rod set including wood handle, rod swivel, brass reduction (male) with metric thread and American thread (5MA/10-32) and brass reduction (female) with metric thread and American thread (7MA/10-32), enabling the use of different productions' accessories.



USA 713
Pomolo bacchetta / Palm saver

Indispensabile per la caccia, questa impugnatura, dotata di vite bloccaggio, permette di utilizzare al meglio la bacchetta di caricamento.

Useful for the hunting, this grip equipped with a blocking screw enables a better use of the loading ramrod of your firearm.

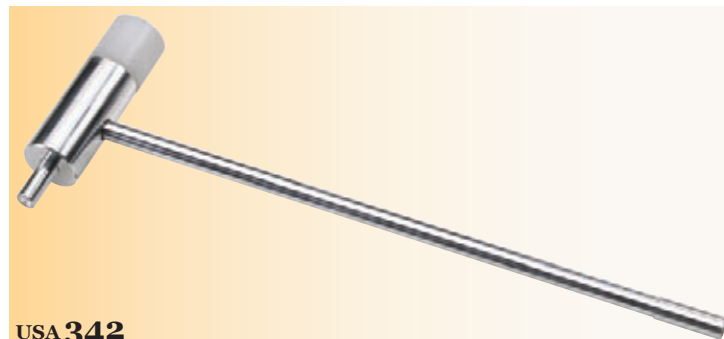

USA 342
Battipalla universale / Universal bullet starter

In alluminio con bacchetta di 320 mm, completo di martello in nylon e due puntali.

With aluminium rod 12 5/8" (320 mm), nylon hammer and two tips.

Code	Ø (mm)	Ø (inches)	Ø puntali / tip (mm)	Ø puntali / tip (inches)
USA 342-07	7	.275	7 - 8	.275 - .315
USA 342-09	9	.275	9 - 10	.354 - .394



USA 700-USA 710
Puntale bacchetta / Rod tip

USA 700 - Puntale in alluminio con filetto femmina 5MA, per bacchette di caricamento.

USA 700 - Aluminium rod tip with female thread 5MA for loading rods.

Code	Ø (mm)	Ø (inches)	Cal.
USA 700-07	7	.275	.31-.32
USA 700-08	8	.315	.36-.38
USA 700-09	9	.354	.40-.41
USA 700-10	10	.394	.44-.45
USA 700-11	11	.433	.50
USA 700-12	12	.472	.54
USA 700-14	14	.551	.69

USA 710 - Puntale in alluminio con filetto maschio 7MA, per battipalla (USA 342).

USA 710 - Aluminium rod tip with male thread 7MA for bullet starter (USA 342).

Code	Ø (mm)	Ø (inches)	Cal.
USA 710-07	7	.275	.31-.38
USA 710-09	9	.354	.40-.50
USA 710-12	12	.472	.54-.58

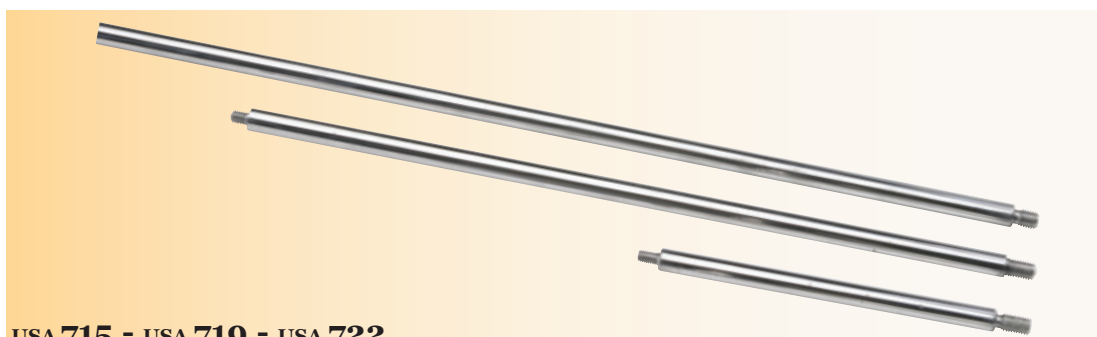

USA 715 - USA 719 - USA 722
Bacchetta alluminio / Aluminium rod

USA 715 - Bacchetta alluminio.
USA 719 - Bacchetta alluminio.
USA 722 - Bacchetta alluminio.

USA 715 - Aluminium rod.
USA 719 - Aluminium rod.
USA 722 - Aluminium rod.

Code	Ø (mm)	Lunghezza Length (mm)	Ø (inches)	Lunghezza Length (inches)
USA 715	9	150	.354	5 7/8
USA 719-07	7	1.000	.275	39 3/8
USA 719	9	1.000	.354	39 3/8
USA 722-07	7	320	.275	12 3/4
USA 722	9	320	.354	12 3/4



USA 712



USA 720



USA 560

USA 712 - Battipalla / impugnatura in nylon.
USA 712 - Bullet starter / nylon handle.
Ø 31x80 mm / 1.220x3 1/8"

USA 720 - Impugnatura alluminio per bacchetta.
USA 720 - Aluminium rod handle.
Ø 27x110 mm / Ø 1.063x4 5/16"

USA 560 - Salvabocca in nylon.
USA 560 - Nylon muzzle protector.

Code	Cal.	Ø bacchetta / rod (mm)	Ø bacchetta / rod (inches)
USA 560-07	.31-.45	7	.275
USA 560-08	.36-.50	8	.315
USA 560-09	.44-.58	9	.354
USA 560-12	.62-.75	12	.472



USA 534-535

USA 534 - Portastraccio con filetto femmina da 5MA.
 USA 535 - Portastraccio con filetto maschio da 10-32.

USA 534 - Jag with female thread: 5MA.
 USA 535 - Jag with male thread: 10-32.

Code	Code	Cal.
USA 534-31	USA 535-31	.31-.32
USA 534-36	USA 535-36	.36-.40
USA 534-45	USA 535-45	.44-.45
USA 534-50	USA 535-50	.50
USA 534-54	USA 535-54	.54
USA 534-58	USA 535-58	.58
USA 534-69	USA 535-69	.69
USA 534-75	USA 535-75	.75



USA 545-546

USA 545 - Cavapalle con filetto femmina da 5MA.
 USA 546 - Cavapalle con filetto maschio da 10-32.
 USA 545 - Bullet puller with female thread: 5MA.
 USA 546 - Bullet puller with male thread: 10-32.

Code	Code	Cal.
USA 545-31	USA 546-31	.31-.32
USA 545-36	USA 546-36	.36-.40
USA 545-45	USA 546-45	.44-.50
USA 545-54	USA 546-54	.54-.58



USA 551-550

USA 550 - Cavastraccio con filetto femmina da 5MA.
 USA 551 - Cavastraccio con filetto maschio da 10-32.
 USA 550 - Patch puller with female thread: 5MA.
 USA 551 - Patch puller with male thread: 10-32.

Code	Code	Cal.
USA 550-31	USA 551-31	.31-.40
USA 550-45	USA 551-45	.44-.50
USA 550-54	USA 551-54	.54-.58
USA 550-69	USA 551-69	.69-.75



USA 555

Cavastraccio e cavaborre con filetto femmina: 5MA, per cal. 12 e cal. 20.
 Patch and cushion wad puller with female thread: 5MA, for 12 ga. and 20 ga.



USA 533-532

USA 532 - Portastraccio con asola con filetto maschio da 10-32 (Ø 9 mm).
 USA 533 - Portastraccio con asola con filetto femmina da 5MA (Ø 9 mm).
 USA 532 - Jag with slot, male thread: 10-32. Ø .354 - 9 mm
 USA 533 - Jag with slot, female thread: 5MA. Ø .354 - 9 mm



USA 739-738-537

USA 537 - Riduzione in ottone con filetto maschio, metrico e americano (5MA / 10-32).
 USA 738 - Riduzione in ottone con filetto femmina, metrico e americano (5MA / 10-32).
 USA 739 - Riduzione in ottone con filetto maschio, metrico e americano (7MA / 10-32).
 USA 537 - Double ended brass screw, metric and American male threads (5MA / 10-32).
 USA 738 - Brass reduction, metric and American female threads (5MA / 10-32).
 USA 739 - Double ended brass screw, metric and American male threads (7MA / 10-32).



USA 733-726

USA 726 - Scovolo crine con filetto maschio da 10-32.
 USA 733 - Scovolo crine con filetto femmina da 5MA.
 USA 726 - Bristle brush with male thread: 10-32.
 USA 733 - Bristle brush with female thread: 5MA.

Code	Code	Cal.
USA 733-31	USA 726-31	.31-.40
USA 733-45	USA 726-45	.44-.50
USA 733-54	USA 726-54	.54-.58
USA 733-69	USA 726-69	.69-.75



USA 734-727

USA 727 - Scovolo bronzo con filetto maschio da 10-32.
 USA 734 - Scovolo bronzo con filetto femmina da 5MA.
 USA 727 - Bronze brush with male thread: 10-32.
 USA 734 - Bronze brush with female thread: 5MA.

Code	Code	Cal.
USA 734-31	USA 727-31	.31-.40
USA 734-45	USA 727-45	.44-.50
USA 734-54	USA 727-54	.54-.58
USA 734-69	USA 727-69	.69-.75



USA 731-729

USA 729 - Scovolo ottone con filetto maschio da 10-32.
 USA 731 - Scovolo ottone con filetto femmina da 5MA.
 USA 729 - Brass brush with male thread: 10-32.
 USA 731 - Brass brush with female thread: 5MA.

Code	Code	Cal.
USA 731-31	USA 729-31	.31-.32
USA 731-36	USA 729-36	.36-.40
USA 731-45	USA 729-45	.44-.45
USA 731-50	USA 729-50	.50
USA 731-54	USA 729-54	.54
USA 731-58	USA 729-58	.58
USA 731-69	USA 729-69	.69/12
USA 731-75	USA 729-75	.75/10



USA 735-732

USA 732 - Scovolo lana con filetto maschio da 10-32.
 USA 735 - Scovolo lana con filetto femmina da 5MA.
 USA 732 - Wool brush with male thread: 10-32.
 USA 735 - Wool brush with female thread: 5MA.

Code	Code	Cal.
USA 735-31	USA 732-31	.31-.40
USA 735-45	USA 732-45	.44-.50
USA 735-54	USA 732-54	.54-.58
USA 735-69	USA 732-69	.69-.75



USA 736-730

USA 730 - Set 3 scovoli, bronzo-lana-crine, con filetto maschio da 10-32.
 USA 736 - Set 3 scovoli, bronzo-lana-crine, con filetto femmina da 5MA.
 USA 730 - 3 brushes set: bronze-wool-bristle with male thread 10-32.
 USA 736 - 3 brushes set: bronze-wool-bristle with female thread 5MA.

Code	Code	Cal.
USA 736-31	USA 730-31	.31-.40
USA 736-45	USA 730-45	.44-.50
USA 736-54	USA 730-54	.54-.58
USA 736-69	USA 730-69	.69-.75



USA 513
Set professionale per armi a pietra focaia / Flint knapper set

Indispensabile per l'utilizzo dell'arma a pietra focaia, è composto da martelletto con estremità in ottone che permette di modellare la pietra focaia; pennellino per la pulizia del bacinetto; spillone per il foro focone; due perni in acciaio ad altissimo tenore di carbonio per avvitare/ svitare il premipietra, utilizzabili per fori piccoli e grandi.

It is very useful for the use of the flintlock's gun, it has a small hammer with brass ends, small brush to clean pan, vent pick, two carbon steel pins to screw/unscrew the top jaw, useful for small and big holes.

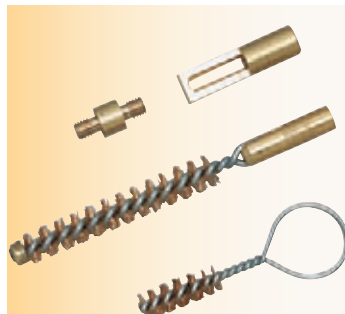

USA 327
Set pulizia tappo canna / Cleaning breech set

Indispensabile per la pulizia delle armi a percussione, è composto da portastraccio con asola, due scovoli in bronzo per la pulizia del filetto tappo canna e portalumino e riduzione in ottone (5MA / 10-32).

Useful for the cleaning of the percussion guns, it has a jag with slot, two bronze brushes to clean the barrel thread cap, nipple drum and a brass reduction (5MA / 10-32).



USA 510
Battipalla / Bullet starter

USA 510 - Battipalla in legno con estremità Ø 9 mm, per calibro .45 e superiori.
USA 510-07 - con estremità Ø 7 mm, per calibro .31 / .36.

USA 510 - Wooden bullet starter Ø .354 (9 mm), for .45 cal. and up.
USA 510-07 - Wooden bullet starter Ø .275 (7 mm), for .31/.36 cal.



USA 512
Martello / Hammer

Martello in legno.
Wooden hammer.



USA 530
Porta olio / Oilcan

Porta olio, in ottone.
Brass oilcan.



USA 060-066-064-065
Portacapsule / Caps holder

USA 060 - Portacapsule lineare Colt Pattern per venti capsule #10 e #11.
USA 064 - Portacapsule lineare per dodici capsule musket a quattro ali.
USA 065 - Portacapsule lineare Zouave per capsule musket senza ali.
USA 066 - Portacapsule lineare Remington Pattern per venti capsule #10 e #11.

USA 060 - Colt Pattern straight line capper for twenty #10 and #11 caps.
USA 064 - Musket straight line capper for twelve musket caps four wings type.
USA 065 - Zouave straight line capper for musket caps without wings.
USA 066 - Remington Pattern straight line capper for twenty #10 and #11 caps.



USA 071

Scatolina portacapsule in ottone, con coperchio.
Brass caps container.



USA 075
Portacapsule / Caps holder

Portacapsule a spirale Colt Pattern per cinquantasette capsule #10 e #11.

Colt Pattern spiral caps holder for fiftyseven #10 and #11 caps.



USA 332
Siringa / Dispenser

Siringa in ottone per revolver, idonea a contenere grasso e vaselina. (Ø 27x165 mm)

Brass grease or lubricant dispenser. Ø 1.063x6 1/2" (27x165 mm)

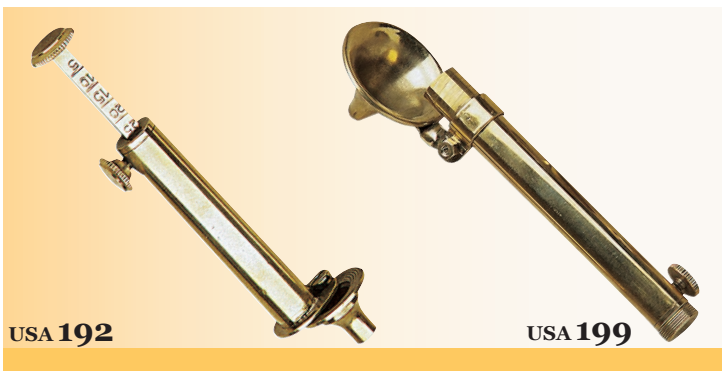

USA 192

USA 199

USA 192 - Misuratore polvere graduato 0-150 grs., con imbuto mobile.

USA 192 - Powder measurer 0-50 grs., with free funnel.

USA 199 - Misuratore polvere graduato 0-150 grs., con imbuto ribaltabile e spillo.

USA 199 - Powder measurer 0-150 grs., with overturning funnel and nipple pick.



USA 189

Misuratore polvere 0-150 grs., con spillo.
Powder measurer 0-150 grs., with nipple pick.



USA 195

USA 196

USA 195 - Misuratore polvere graduato 0-150 grs., con imbuto mobile e spillo.

USA 195 - Powder measurer 0-150 grs., with movable funnel and nipple pick.

USA 196 - Misuratore polvere graduato 0-150 grs., con imbuto lungo ribaltabile e spillo.

USA 196 - Powder measurer 0-150 grs., with overturning long funnel and pick.



USA 197

Misuratore volumetrico per polvere e piombo.
Powder and shot volume measurer.



USA 540

Misuratore regolabile per polvere e piombo.
Adjustable powder and shot measuring.

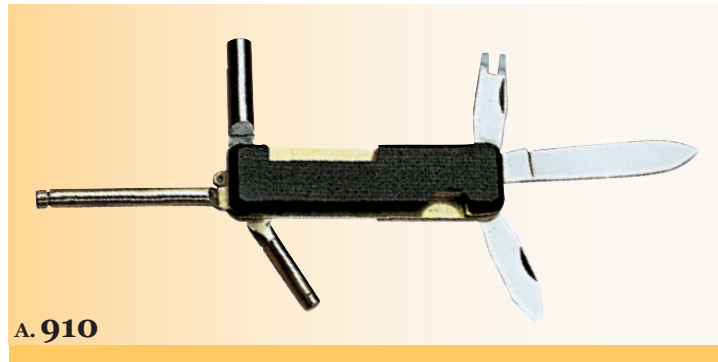

A. 910

Coltello Multiuso, completo di lama e cinque accessori per il caricamento: cacciavite, chiave luminello, estrattore per capsule e chiavetta, bullet starter lungo e portacapsule in ottone, bullet starter corto con spillo, riduzione con filetto maschio (5MA) per bacchetta.

Possible tool knife with blade and five accessories: screw driver, nipple wrench, caps and wedge puller, brass long bullet starter and caps holder, short bullet starter with nipple pick, rod reducer with male thread (5MA).



USA 338

Imbuto in ottone in tre pezzi. Ø 8x1.110 mm.
Brass funnel, (3 pieces). - Ø .315x43 11/16" (8x1.110 mm).



USA 085

Iniettore polvere per armi a pietra focaia.
Pan primer.

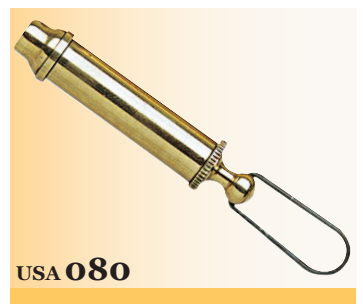

USA 080

Iniettore polvere per armi a percussione.
Nipple charger.

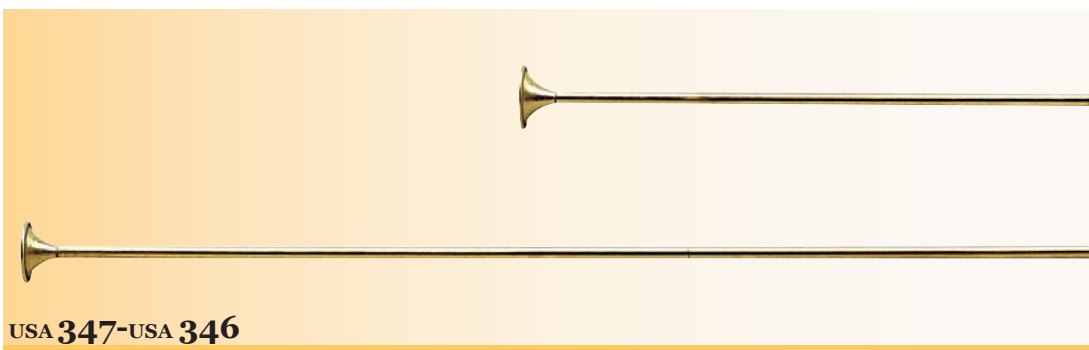

USA 347-USA 346

USA 346 - Imbuto in ottone, per caricamento fucili.

USA 346 - Drop tube for loading black powder rifles and cartridge cases.

USA 347 - Imbuto in ottone per caricamento pistole.

USA 347 - Brass loading funnel for pistols.

Code	Ø (mm)	Length (mm)	Ø (inches)	Length (inches)
USA 346-07	7	960	.275	37 13/16
USA 346	8	960	.315	37 13/16
USA 347-07	7	380	.275	15
USA 347	8	380	.315	15



USA 336A

USA 336-A
Set pulizia, caricamento e sparo per armi a percussione.

USA 336-B
Set pulizia, caricamento e sparo per armi a pietra focaia.

USA 336-A
Cleaning, loading and shooting set for percussion firearms.

USA 336-B
Cleaning, loading and shooting set for flintlock firearms.



USA 336B

Code	Code	Cal.
USA 336-36A	USA 336-36B	.36-.40
USA 336-45A	USA 336-45B	.44-.50
USA 336-54A	USA 336-54B	.54-.58
USA 336-69A	USA 336-69B	.69-.75



USA 337A

USA 337-A - Set Sparo "Basic" per armi a percussione, completo di: quaranta provette in vetro da 100 grs., una chiave luminello con adattatore per i luminelli musket, una fiaschetta tubolare in ottone, un misuratore polvere e una confezione di Solblack. (cc. 100)

USA 337-A - "Basic" Shooting set for percussion guns, complete with 40 glass bottles 100 grs., nipple wrench with musket nipple converter, brass tubular flask, powder measure and 100 cc. of Solblack solvent.



USA 337B

USA 337-B - Set Sparo "Basic" per armi a pietra focaia, completo di: quaranta provette in vetro da 100 grs., un pan primer, uno spillone, una fiaschetta porta polvere, un misuratore di polvere e una confezione da 100 cc. di Solblack.

USA 337-B - "Basic" Shooting set for flintlock guns, complete with 40 glass bottles 100 grs., pan primer, vent pick, powder flask, powder measure and 100 cc. of Solblack solvent.



USA 324

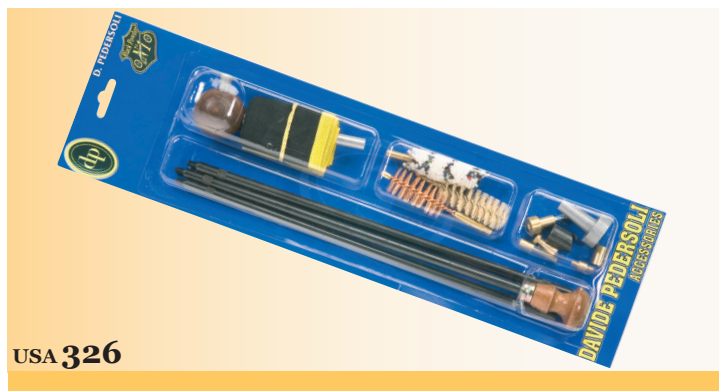

USA 326

USA 324 - Set pulizia e caricamento Deluxe, in scatola di plastica, caratterizzato da bacchetta in alluminio in 4 pezzi (tot. 1.135 mm) e impugnatura girevole in legno.

USA 324 - Deluxe cleaning and loading tool set, characterized by a clear view plastic box, aluminium rod 4 pieces (total length 44¹¹/₁₆"/1.135 mm) and swivel handle.

USA 326 - Set pulizia e caricamento in blister.

USA 326 - Cleaning and loading tool set in blister.



USA 331

USA 331 - Set pulizia e caricamento per revolver.

USA 331 - Cleaning and loading tool set for revolver.

Code	Cal.
USA 324-38	.38-.40
USA 324-45	.44-.50
USA 324-54	.54-.58
USA 324-69	.69-.75
USA 326-36	.36-.40
USA 326-45	.44-.50
USA 326-54	.54-.58
USA 326-69	.69-.75
USA 331-36	.36
USA 331-44	.44



USA 525
Tendimolla / Mainspring vise

Indispensabile per lo smontaggio della molla del cane dagli acciarini.

Mainspring vise.



USA 527
Tendimolla Lafayette / Lafayette mainspring vise

Elegante morsetto tendimolla con appoggi mobili adattabili a qualsiasi molla del cane per lo smontaggio degli acciarini. Presenta una robusta vite di serraggio dotata di un'ampia aletta di presa.

An elegant mainspring vise with movable and adjustable clamps fits any mainspring to disassemble the lock. It features a strong screw with an easy grip to firmly clamp.



USA 486
Tubo pulizia / Cleaning tube

Tubo universale per la pulizia delle armi ad avancarica a percussione.

Cleaning tube for percussion muzzle loading firearms.



USA 511
Tubo pulizia / Cleaning tube

Tubo universale per la pulizia delle armi ad avancarica a pietra focaia.

Cleaning tube for flintlock muzzle loading firearms.



USA 496
Espulsore palle / Fast bullet puller

Utilissimo per l'espulsione delle palle dalla canna, è fornito con due bombolette di CO₂. Completo di tre adattatori per luminelli con filetto: $\pm 1/4''-28$ UNF / $\pm 5/16''$ UNF - M6x1.

Allows removal of bullet without firing the gun! Pulls bullets using CO₂ gas bottles. It is equipped with three adapters for nipple threads: $\pm 1/4''-28$ UNF / $\pm 5/16''$ UNF / M6x1 and completed with two CO₂ gas bottles.



USA 500
Estrattore camerina flottante / Gas check moving tool

USA 500-45 / calibro .45
USA 500-54 / calibro .54
Utilizzato nei modelli Sharps a cartuccia di carta per facilitare la parziale estrazione della camerina flottante, che comunque non può essere rimossa completamente.

USA 500-45 / .45 caliber
USA 500-54 / .54 caliber
Very useful tool to move slightly the gas check of the Sharps 1859-1863 paper cartridges models. We remind you that the gas check cannot be removed completely.



USA 517

Confezione 10 bossoli in ottone per fucile 1859-1863 Sharps.

10 brass case for 1859-1863 Sharps rifles bag.

Code	Cal.	Tipo palla / Bullet design
USA 517-451	.45	Stile originale / Original design
USA 517-54A	.54	Stile moderno / Modern design
USA 517-54B	.54	Stile originale / Original design



USA 208

Set per la preparazione delle cartucce di carta per i modelli 1859-1863 Sharps. È composto da 100 fogli di carta nitrata, imbuto in plastica, colla e mandrino in acciaio per l'avvolgimento della carta.

Paper cartridge set for the 1859-1863 Sharps rifles percussion models. Made of 100 nitrate paper sheets, plastic funnel, glue stick and a forming dowel to roll the paper.

Code	Cal.
USA 208-45	.45
USA 208-54	.54



USA 207

USA 207-45 / .45 caliber
USA 207-54 / .54 caliber
Set 100 fogli carta nitrata.
100 nitrate paper sheets.

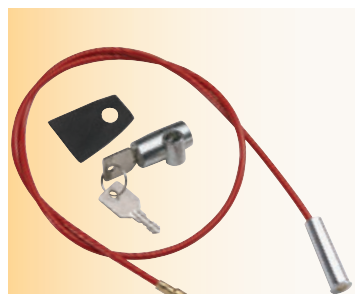

USA 063
Safety lock

Un sistema di sicurezza semplice, immediato ed efficace per prevenire qualsiasi uso improprio o accidentale del vostro fucile. È costituito da un piccolo cavo d'acciaio che riporta a una estremità una falsa cartuccia da introdurre nella camera di scoppio della canna e, all'altra estremità, un lucchetto dotato di chiave. Una membrana di gomma protegge la volata dal contatto con il lucchetto. Disponibile con cavetto di diverse lunghezze e nei calibri .45 e .50.

A simple, efficient and quick safety system to prevent an improper or accidental use of your gun. It is made of a thin steel rope having a false cartridge to one end to place into the chamber and to the other end a padlock with key. A rubber ring protects the muzzle.

Available with different steel rope lengths for the .45 and .50 calibers.

Code	Cal.	Lung. Canna Barrel length (inches)	Lung. Canna Barrel length (mm)
USA 063-45A	.45	22"	559
USA 063-45B	.45	24"	610
USA 063-45C	.45	30"	762
USA 063-45D	.45	32"	812
USA 063-45E	.45	34"	864
USA 063-45F	.45	28"	711
USA 063-50E	.50	34"	864



Code	Cal.	Ø (mm)	Spessore Thick (mm)	Ø (inches)	Spessore Thick (inches)	Code	Cal.	Ø (mm)	Spessore Thick (mm)	Ø (inches)	Spessore Thick (inches)
0531	.31	20	0,12	.787	.005	0554	.54/.58	32	0,12	1.260	.005
0731	.31	20	0,18	.787	.007	0754	.54/.58	32	0,18	1.260	.007
1031	.31	20	0,25	.787	.010	1054	.54/.58	32	0,25	1.260	.010
1231	.31	20	0,31	.787	.012	1254	.54/.58	32	0,31	1.260	.012
1531	.31	20	0,38	.787	.015	1554	.54/.58	32	0,38	1.260	.015
1631	.31	20	0,42	.787	.016	1654	.54/.58	32	0,42	1.260	.016
1831	.31	20	0,47	.787	.018	1854	.54/.58	32	0,47	1.260	.018
2331	.31	20	0,58	.787	.023	2354	.54/.58	32	0,58	1.260	.023
0536	.36/.41	24	0,12	.945	.005	0562	.62/.69	38	0,12	1.496	.005
0736	.36/.41	24	0,18	.945	.007	0762	.62/.69	38	0,18	1.496	.007
1036	.36/.41	24	0,25	.945	.010	1062	.62/.69	38	0,25	1.496	.010
1236	.36/.41	24	0,31	.945	.012	1262	.62/.69	38	0,31	1.496	.012
1536	.36/.41	24	0,38	.945	.015	1562	.62/.69	38	0,38	1.496	.015
1636	.36/.41	24	0,42	.945	.016	1662	.62/.69	38	0,42	1.496	.016
1836	.36/.41	24	0,47	.945	.018	1862	.62/.69	38	0,47	1.496	.018
2336	.36/.41	24	0,58	.945	.023	2362	.62/.69	38	0,58	1.496	.023
0545	.45/.50	28	0,12	1.102	.005	0575	.75	42	0,12	1.653	.005
0745	.45/.50	28	0,18	1.102	.007	0775	.75	42	0,18	1.653	.007
1045	.45/.50	28	0,25	1.102	.010	1075	.75	42	0,25	1.653	.010
1245	.45/.50	28	0,31	1.102	.012	1275	.75	42	0,31	1.653	.012
1545	.45/.50	28	0,38	1.102	.015	1575	.75	42	0,38	1.653	.015
1645	.45/.50	28	0,42	1.102	.016	1675	.75	42	0,42	1.653	.016
1845	.45/.50	28	0,47	1.102	.018	1875	.75	42	0,47	1.653	.018
2345	.45/.50	28	0,58	1.102	.023	2375	.75	42	0,58	1.653	.023

Set 100 pezze professionali / 100 profi-patches bag



Set 1.000 cartoncini.
1000 carton over shot wads bag.

Code	Cal.	Spessore Thick (mm)	Spessore Thick (inches)
USA 086-12	12	1,20	.047
USA 086-20	20	1,20	.047

USA 086
Cartoncini / Carton wads



USA 087 - Set 200 borre in sughero.
USA 087 - 200 cork cushion wads bag.
USA 093 - Set 200 borre in sughero.
USA 093 - 200 cork over powder wads bag.

Code	Cal	Spessore Thick (mm)	Spessore Thick (inches)
USA 087-12	12	20	.787
USA 087-20	20	20	.787
USA 093-12	12	3	.118
USA 093-20	20	3	.118

USA 087-093
Borre sughero / Cork wads



Confezione 200 borre in feltro.
200 felt wads bag.

Code	Cal.	Ø (mm)	Ø (inches)	Spessore Thick (mm)	Spessore Thick (inches)	Code	Cal.	Ø (mm)	Ø (inches)	Spessore Thick (mm)	Spessore Thick (inches)
USA 094-36	.36	10	.394	10	.394	USA 098-36	.36	10	.394	6	.236
USA 094-44	.44	12	.472	10	.394	USA 098-44	.44	12	.472	6	.236
USA 094-50	.50	13	.512	10	.394	USA 098-50	.50	13	.512	6	.236
USA 094-54	.54	14	.551	10	.394	USA 098-54	.54	14	.551	6	.236
USA 094-58	.58	15	.590	10	.394	USA 098-58	.58	15	.590	6	.236
USA 094-69	.69	18	.709	10	.394	USA 098-69	.69	18	.709	6	.236
USA 094-75	.75	19	.748	10	.394	USA 098-75	.75	19	.748	6	.236

USA 094
Borre peltro / Felt wads

USA 098



Confezione 15 provette plastica.
15 plastic bottles bag, with integral top cap.

Code	Misura / Size
USA 231-25	40 grs
USA 231-50	80 grs
USA 231-100	120 grs

USA 231
Provette / Bottles



USA 203 - 50 - Nuovo Match set con interno in spugna, completo di quaranta provette in vetro 50 grs.

USA 203 - 50 - New Match set with sponge lining inside, complete with 40 glass bottles 50 grs.

USA 203-100 - Nuovo Match set con interno in spugna, completo di trentotto provette in vetro 100 grs.

USA 203-100 - New Match set with sponge lining inside, complete with 38 glass bottles 100 grs.

USA 203
Match set



USA 088
 Confezione 200 capsule grandi RWS, quattro ali.
USA 088
 200 RWS percussion musket caps four wings box.
USA 089
 Confezione 100 capsule RWS.
USA 089
 100 RWS percussion caps box.
USA 089-P
 Confezione 100 capsule RWS Plus.
USA 089-P
 100 RWS Plus percussion caps box.



Confezione cinque pietre focaie in selce.
 Five flints bag.

Code	Misura ca. est. Size (inches)
USA 090	1
USA 090-1	7/8
USA 091	3/4
USA 091-1	5/8



Confezione 500 pallini ramati.
 500 copper pellets box.

Code	Cal.
USA 082	4,5 mm
USA 082-43	4,3 mm



Confezione tre morsetti in piombo, per pietre focaie.
 Three lead flint clamps bag.



Confezione 2,5 kg pallini in piombo n.7.
 (Misuratore piombo non incluso).

5.51 lbs (2,5 kg) lead shot no.7 jar.
 (Powder shot measuring not included).



Set 250 straccetti per la pulizia dei residui della polvere nera combusta.

250 cleaning cloth patches set to clean the black powder guns.

Code	Cal.	Misura Size (mm)	Misura Size (mm)
USA 497-040	.30/.41	40x40	1 ⁹ / ₁₆ X 1 ⁹ / ₁₆
USA 497-050	.44/.58	50x50	2 X 2
USA 497-060	.62/.75	60x60	2 ³ / ₈ X 2 ³ / ₈

USA 096

USA 497
 Straccetti pulizia / Cleaning patches



Set "Cleaning & Lube" per polvere nera, ideale per l'impiego e la manutenzione delle armi ad avancarica, contiene un flacone di Solblack (cc.100), un flacone di Dunlubri (cc. 20) e un tubetto di Lubriblack. (cc. 50)

"Cleaning & Lube" set for black powder, ideal for the use and maintenance of muzzle loading guns. It contains a bottle (100 cc.) Solblack solvent, a bottle (20 cc.) Dunlubri oil and a tube (50 cc.) Lubriblack bullet grease.

USA 341
 Set "Cleaning & Lube"/ "Cleaning & Lube" set

USA 487 - Solblack - Detergente per lavaggio residui polvere nera, con vaporizzatore. ml. 1000e

USA 487 - Solblack - Solvent to clean black powder foul residue, with sprayer. - 1000 ml.

USA 487-B - Solblack - ml. 1000e
 USA 487-R - Solblack - ml. 500e

USA 488 - Lubriblack - Grasso per palle. g 100e
 USA 488 - Lubriblack - Grease for bullets. g 100e

USA 488-B - Lubriblack - g 250e

USA 491 - Dunlubri - Lubrificante fluido per pezzi ad alto potere penetrante. - cc. 50
 USA 491 - Dunlubri - Patches fluid oil with penetrating property. - cc. 50.

USA 491 - USA 487B - USA 487R - USA 487 - USA 488B - USA 488
 Dunlubri - Solblack - Lubriblack

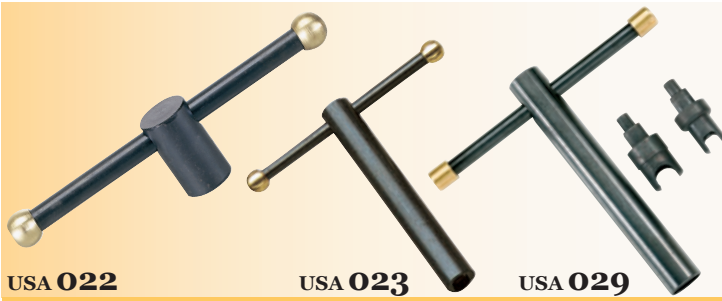

USA 022

USA 023

USA 029

USA 022 - Chiave luminello corta a T, realizzata in materiale ad alto tenore di carbonio e con spacco luminello incassato da 6 mm ca. Ideale per Mang in Graz e Kuchenreuter.
USA 022 - Alloy steel "T" short nipple wrench having inscribed nipple slot of about .236" (6 mm).
 Ideal for Mang in Graz and Kuchenreuter pistol models.

USA 023 - Chiave luminello a T, realizzata in materiale ad alto tenore di carbonio, con spacco luminello incassato da 6 mm ca.
USA 023 - Alloy steel "T" nipple wrench having inscribed nipple slot of about .236" (6 mm).

USA 029 - Chiave luminello a T, realizzata in materiale ad alto tenore di carbonio, con spacco luminello incassato da 6 mm ca., completata da due adattatori con spacco luminello da 5 e 7 mm ca.
USA 029 - Alloy steel "T" nipple wrench having inscribed nipple slot of about .236" (6 mm), complete with two nipple adapters with slots of about .196" (5 mm), and .275" (7 mm).

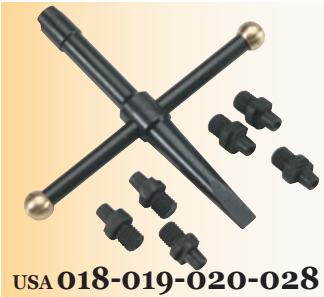

USA 018-019-020-028

USA 018 - Set chiave USA 015 con 6 luminelli USA 471
USA 018 - Nipple wrench USA 015 with six nipples USA 471 set.
USA 019 - Set chiave USA 015 con 6 luminelli USA 477
USA 019 - Nipple wrench USA 015 with six nipples USA 477 set.
USA 020 - Set chiave USA 015 con 6 luminelli USA 498
USA 020 - Nipple wrench USA 015 with six nipples USA 498 set.
USA 028 - Set chiave USA 027 con 6 luminelli USA 470
USA 028 - Nipple wrench USA 027 with six nipples USA 470 set.



USA 027-037

USA 027 - Chiave luminello Deluxe a T con spillo, realizzata in materiale ad alto tenore di carbonio, con spacco luminello incassato da 6 mm ca.
USA 027 - Deluxe alloy steel "T" wrench with pick, having inscribed nipple slot of about .236" (6 mm).

USA 037 - Chiave luminello Musket a T con spillo, realizzata in materiale ad alto tenore di carbonio, con spacco luminello incassato da 7 mm ca.
USA 037 - Musket alloy steel "T" wrench with pick, having inscribed nipple slot of about .275" (7 mm).

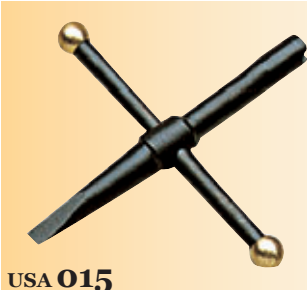

USA 015



USA 016

USA 015 - Chiave luminello a croce, per revolver, con spacco luminello da 5 mm ca. e con cacciavite.
USA 015 - Cruciform wrench, for revolver, having nipple slot of about .196" (5 mm) and screw driver tip.

USA 016 - Chiave luminello Universale a croce con spacco luminello da 5, 6 e 7 mm ca. e con cacciavite.
USA 016 - Universal cruciform carbon steel wrench with nipple slots of about .196" (5 mm), .236" (6 mm) and .275" (7 mm), and screw driver tip.



USA 035

Chiave luminello Walker con spacco luminello da 5 mm ca. e con cacciavite.
Walker wrench having nipple slot of about .196" (5 mm) and screw driver tip.



USA 041

USA 043

USA 045

USA 046

USA 041 - Baby - Chiave luminello a L per revolver, con spacco luminello da 4,5 mm ca. e con cacciavite.
USA 041 - Baby wrench with nipple slot of about .177" (4,5 mm) and screw driver tip.

USA 043 - Baby Deluxe - Chiave luminello a L per revolver, realizzata con materiale ad alto tenore di carbonio, con spacco luminello da 4,5 mm ca.
USA 043 - Baby Deluxe - Alloy steel "L" wrench having nipple slot of about .177" (4,5 mm).

USA 045 - Colt Pattern - Chiave luminello L

per revolver, con spacco luminello da 5 mm ca. e con cacciavite.
USA 045 - Colt Pattern wrench with nipple slot of about .196" (5 mm) and screw driver tip.

USA 046 - Colt Pattern Deluxe - Chiave luminello a L per revolver, realizzata con materiale ad alto tenore di carbonio, con spacco luminello da 5 mm ca.
USA 046 - Colt Pattern Deluxe - Alloy steel "L" wrench having nipple slot of about .196" (5 mm).



USA 010-011-012

USA 010 - Cacciavite con manico in legno.
USA 010 - Screwdriver, with wooden handle.

USA 011 - Chiave luminello con manico in legno, con spacco luminello da 5 mm ca.
USA 011 - Nipple wrench with wooden handle, having nipple slot of about .196" (5 mm).

USA 012 - Chiave luminello con manico in legno con spacco luminello da 6 mm ca.
USA 012 - Nipple wrench with wooden handle, having nipple slot of about .236" (6 mm).



USA 475 - 485
 Foconi & Set foconi / Flash hole & Flash hole sets

USA 475 - Focone in acciaio (M8x1,25).
USA 475 - Steel flash hole (M8x1,25).

USA 485 - Focone al berillio (M8x1,25).
USA 485 - Beryllium flash hole (M8x1,25)

USA 475-3 - Set 3 foconi in acciaio.
USA 475-3 - Set 3 steel flash hole.

USA 485-3 - Set 3 foconi al berillio.
USA 485-3 - Set 3 beryllium flash hole.

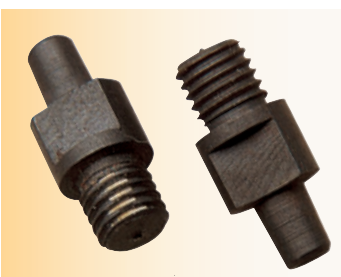

Code Luminelli acciaio Steel nipples	Code Luminelli berillio Beryllium nipples	Misura Size	Arma Gun
USA 460	USA 482	M6x0,75	Underhammer "Pedersoli"
USA 470	USA 484	≠ 1/4"-28 UNF	"Pedersoli" guns
USA 471	USA 499	M6x0,75	Rogers & Spencer "Pedersoli" / "Euroarms"
USA 477	USA 502	N° 12 - 28 UNF	Remington "Pedersoli" / "Uberti"
USA 478	USA 504	≠ 1/4"-28 UNF	Musket caps
USA 479	-	≠ 1/4"-28 UNF	Zimmer / Saloon cal. 4,5 mm
USA 480	USA 503	≠ 5/16" UNF	Sharps / Musket caps
USA 498	-	M6x0,75	Coil "Pietta"

Code Luminelli acciaio Steel nipples	Code Luminelli berillio Beryllium nipples	Misura Size	Arma Gun
USA 505	-	≠ 5/16" UNF	Württembergischen / Musket caps
USA 506	-	≠ 1/4"-28 UNF	Zimmer / Saloon cal. .36

Code Set luminelli acciaio Steel nipples set	Code Set luminelli berillio Beryllium nipples set	Descrizione Descriptions	Arma Gun
USA 470-3	USA 484-3	set 3 luminelli 3 nipples set	"Pedersoli" guns
USA 471-6	USA 499-6	set 6 luminelli 6 nipples set	Rogers & Spencer "Pedersoli" / "Euroarms"
USA 477-6	USA 502-6	set 6 luminelli 6 nipples set	Remington "Pedersoli" / "Uberti"



Coltelli / Knives

Lama in acciaio DIN 430 - 59 H_{RC}, satinata. Puntale e guardia in acciaio inox. Impugnatura in acero e fodero in cuoio.

A. 917 - Coltello Bowie
Lunghezza lama: 181 mm
Spessore lama: 5 mm
Lunghezza totale: 291 mm

A. 919 - Coltello Boot
Lunghezza lama: 140 mm
Spessore lama: 5 mm
Lunghezza totale: 250 mm

A. 916 - Coltello Rezin Bowie
Caratterizzato da ornamenti argentati sull'impugnatura in legno. Fodero in cuoio color nero. Lunghezza lama: 240 mm
Lunghezza totale: 370 mm

A. 915 - Coltello Rezin Bowie Deluxe
Versione Deluxe con fodero in cuoio completato da puntale e collare in "German silver".

Polished steel blade, DIN 430 - 59 H_{RC}, stainless steel fittings and maple handle. With hard leather sheath.

A. 917 - Bowie knife
Blade length: 7¹/₈" (181 mm)
Blade thickness: 3/16" (5 mm)
Overall length: 11¹/₂" (291 mm)

A. 919 - Boot knife
Blade length: 5¹/₂" (140 mm)
Blade thickness: 3/16" (5 mm)
Overall length: 9⁷/₈" (250 mm)

A. 916 - Rezin Bowie knife
Enriched with silver plated fittings and ornaments on the wooden handle. Steel blade, hard leather, black colour sheath. Blade length: 9⁷/₁₆" (240 mm)
Overall length: 14⁹/₁₆" (370 mm).

A. 915 - Rezin Bowie Deluxe knife
Deluxe Rezin Bowie version with a "German silver" mounted sheath.

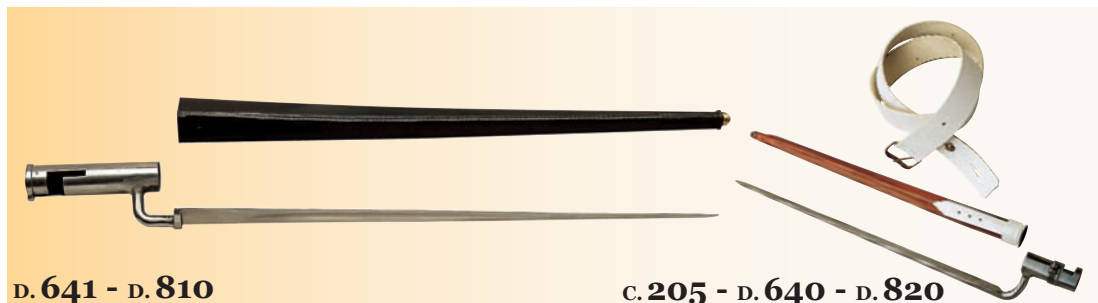

D. 641 - D. 810
Baionette / Bayonets

C. 205 - D. 640 - D. 820

D.641 - Fodero per baionetta Brown Bess.
D.810 - Baionetta per Brown Bess.
C.205 - Cinghia per 1777 - 1777/An IX.
D.640 - Fodero per baionetta 1777 - 1777/An IX.
D.820 - Baionetta per 1777 - 1777/An IX.
D.641 - Bayonet scabbard for Brown Bess.
D.810 - Bayonet for Brown Bess musket.
C.205 - Leather sling for 1777 - 1777/An IX.
D.640 - Bayonet scabbard for 1777 - 1777/An IX.
D.820 - Bayonet for 1777 - 1777/An IX musket.



SC 923
Briquet Napoleonico / Napoleonic Infantry Sword (curved briquet style)

Riproduzione fedele di briquet napoleonico da fanteria, con fodero in cuoio. Particolarmente indicato per le rievocazioni storiche del periodo Napoleonico, è realizzato in acciaio, con elsa in ottone e lama (59 cm) non tagliente. Peso: kg 1.000 (2.21 lbs)

Faithful reproduction of both the sword and leather scabbard.
Suitable for Napoleonic historical re-enactment events. Hilt is brass and the 23,2" (59 cm) steel blade is not sharpened.
Weight: 2.21 lbs (kg 1,000)



USA 400
Cacciaviti / Screwdrivers

Set dodici cacciaviti, indispensabile per i collezionisti, e ideale per la Vostra arma. Le lame sagomate permettono di operare su qualsiasi tipo di vite europea e americana di arma da fuoco. Un appropriato trattamento di indurimento ne assicura la lunga durata nel tempo. I manici, in legno completano le lame in acciaio. È confezionato con astuccio in pelle morbida.

A set of 12 firearm screwdrivers to complete a chore on your fine gun.
The slotted blades suite all European and American slotted screws on your firearm.
The blades hardening treatment ensures a long lasting use, featuring wood handles and packed in a soft leather case.



D. 647

Fodero in pelle morbida realizzati completamente a mano. Ideali per tutti i modelli di armi della frontiera.

- D. 642 - Fodero corto per fucile (105 cm).
- D. 643 - Fodero lungo per fucile (130 cm).
- D. 647 - Fodero extra-lungo per fucile (156 cm).



D. 642

Soft leather gun covers, totally hand-made, are the classic for black powder and cartridge firearms.

- D. 642 - Short leather gun cover (41³/₈" / 105 cm).
- D. 643 - Long leather gun cover (51¹/₄" / 130 cm).
- D. 647 - Extra-long leather gun cover (61¹/₂" / 156 cm).



D. 643

Fodero / Gun covers



USA 604-11



USA 604-13



USA 375

Sacchetto porta palle, in pelle.

Leather bullet bag.



USA 604-19

Cappelli / Hats



USA 605



D. 644

Cartuccera / Cartridge belt

Cartuccera in cuoio, rivestita in cotone per calibro .45.

Leather Cartridge belts cloth covered, for all .45 caliber rifle cartridges.

Code	Misura / Size (cm)	Misura / Size (inches)
D.644-A	120	47 ¹ / ₄
D.644-B	110	43 ⁵ / ₁₆

Cappelli realizzati a mano, in lana, molto leggeri, rifiniti con interni speciali in pelle e fodere in raso.

- USA 604-11: Buckaroo (nero)
- USA 604-13: Ufficiale Federale (blu)
- USA 604-19: River Side (marrone)

Lightweight wool hats, hand made, leather and satin lining.

- USA 604-11: Buckaroo (black)
- USA 604-13: Federal (blue)
- USA 604-19: River Side (brown)

USA 605 - "Wind River" - Cappello realizzato a mano, in feltro di lepre leggero e impermeabile, rifinito con interno in pelle e fodera in raso.

USA 605 - "Wind River" - Hand made hat, 100% hare felt, lightweight, water resistant, satin and leather lining.

	Taglia / Size				
Europe	56	57	58	59	60
U.S.A.	7"	7 ¹ / ₈ "	7 ¹ / ₄ "	7 ³ / ₈ "	7 ¹ / ₂ "



USA 355 - Cofanetto in mogano, per una pistola. (433x220 mm)
USA 355 - Mahogany case, for pistol. (17¹/₁₆"x8¹¹/₁₆" / 433x220 mm)
USA 389 - Cofanetto vetrina, in mogano per una pistola. (433x220 mm)
USA 389 - Glass show case made of mahogany for pistol. (17¹/₁₆"x8¹¹/₁₆" / 433x220 mm)
USA 367 - Cofanetto in mogano, per due pistole e quattro accessori. (485x290 mm)
USA 367 - Mahogany case, for two pistol and four accessories. (19¹/₈"x11⁷/₁₆" / 485x290 mm)

USA 355

USA 389

USA 367



USA 360 - Cofanetto in legno, per pistole e accessori. (410x170 mm)
USA 360 - Wooden case for pistol and accessories. (16¹/₈"x6¹¹/₁₆" / 410x170 mm)
USA 361 - Cofanetto in mogano per una pistola e otto accessori. (485x290 mm)
USA 361 - Mahogany case, for pistol and eight accessories. (19¹/₈"x11⁷/₁₆" / 485x290 mm)
USA 363 - Cofanetto in mogano per due pistole e otto accessori. (485x405 mm)
USA 363 - Mahogany case, for two pistol and eight accessories. (19¹/₈"x15⁵/₁₆" / 485x405 mm)

USA 361-363

USA 360



Cofanetto in legno per revolver e accessori. (350x165 mm)
 Wooden case for revolver and accessories. (13¹³/₁₆"x 6¹/₂" / 350x165 mm)

USA 350



Valigetta "Pedersoli" Super Match per pistola o revolver, completa di quindici provette in plastica 50 grs. È dotata di chiusura a combinazione e omologata per il trasporto aereo. (460x185 mm)
 "Pedersoli" Super Match gun case with safety lock, including 15 plastic powder measuring 50 grs. Homologated for air transport. (18¹/₈"x7¹/₄" / 460x185 mm)

USA 390



Valigetta Deluxe "Pedersoli" per pistola o revolver, con finiture in pelle e interno sagomato in velluto, dotata di chiusura a combinazione e omologata per il trasporto aereo. (460x230 mm)
 Deluxe "Pedersoli" pistol case, leather finish with velveteen lining and safety lock. Homologated for air transport. (18¹/₈"x9¹/₁₆" / 460x230 mm)

USA 393



USA 364

Pannello in legno rivestito in panno, per pistola. (465x265 mm)

Wooden display panel, with cloth lining, for pistol. (18⁵/₁₆"x10⁷/₁₆" / 465x265 mm)



USA 391

Valigetta professionale "Pedersoli" per pistola o revolver, e accessori. (495x200x h.330 mm - chiusa).

Professional "Pedersoli" case for guns and accessories. (19¹/₂"x7⁷/₈" xH 13" / 495x200x H.330 mm - closed)



USA 392
Valigetta fucile / Gun case

Valigetta "Pedersoli" per fucile, con finiture in pelle e interno sagomato in velluto, dotata di chiusura a combinazione e omologata per il trasporto aereo. (1.320x210 mm)

"Pedersoli" gun case, leather finish with velveteen lining and safety lock. Homologated for air transport. (52"x8 1/4" / 1.320x210 mm)



USA 374
Espositore per fucile / Display racks

USA 372 - Espositore per fucile
USA 374 - Espositore con chiusura per fucile
Coppia di supporti modulari trasparenti da posizionare su un piano oppure, se privati del sostegno triangolare posteriore, fissati a una parete. I supporti presentano una diversa sagomatura del profilo interno, così da potere ospitare, rispettivamente, sia il calcio sia la canna dell'arma. Nella configurazione con chiusura (USA 374), il supporto destinato al calcio è completato con un gancio per il bloccaggio dell'arma.

USA 372 - Display racks
USA 374 - Display racks with lock
Couple of modular, clear view display racks to place on a flat surface or to hang on the wall. The racks feature two different inside profiles to support the gun's stock and the barrel. The USA 374 is completed with a lock where the gun's stock is placed.



USA 608
Pomoli legno / Gun pegs

Pomoli in legno completi di viti per il fissaggio alle pareti, ideali per l'esposizione di fucili e/o pistole.

Wooden gun pegs completed with screws to be fixed to the walls, useful for the displaying of guns or pistols.



USA 650
Borsa da tiro / Match bag

Borsa da tiro "Pedersoli", in nylon, porta pistola e accessori, provvista di fondo rigido rivestito in spugna.

"Pedersoli" nylon Match bag, for hand guns and accessories, with inside sponge lined hard bottom.



USA 620

Distintivo "Pedersoli" in stoffa, ricamato, termosaldaibile per una facile applicazione.

"Pedersoli" patch embroidered in gold colour letters.



USA 610-1
"Pancho Villa"



USA 610-2
"La Sfida" / "The Challenge"

USA 610 - "Pedersoli" T-shirt grigia Hanes, in quattro serie umoristiche, firmate dal noto vignettista Fabrizio Zubani. Sul retro è riportato il marchio "Black Powder N° 1", nuovo brand della Davide Pedersoli. Disponibile nelle taglie S, M, L, XL.

USA 610 - "Pedersoli" T-shirt, Hanes 100% cotton made grey colour, four humorous characters signed by the well known Italian illustrator Fabrizio Zubani. On the back there is the "Black Powder N° 1" logo, Davide Pedersoli's brand. Available sizes S, M, L, XL.

USA 610-1 - "Pancho Villa"
USA 610-2 - "La Sfida" / "The Challenge"
USA 610-3 - "Geronimo"
USA 610-4 - "Zorro". Sul retro è riportato il marchio realizzato in occasione del 50° anniversario della Davide Pedersoli. / On the back there is the special 50th Anniversary logo of Davide Pedersoli.



USA 600-2
Cappellino / cap

Cappellino da tiro "Pedersoli" in cotone con colori grigio e nero e marchio ricamato.
"Pedersoli" shooting cap, 100% cotton made grey and black colours with embroidered logo.



USA 610-3
"Geronimo"



USA 610-4
"Zorro"



USA 619
Carte da gioco / Far West paying cards

Carte da gioco Far West "50° Anniversario Davide Pedersoli", illustrate con simpatiche caricature firmate da Fabrizio Zubani.

Far west playing cards "50th Davide Pedersoli Anniversary", with humorous characters signed by Fabrizio Zubani.



USA 634-004

Le Page a pietra focaia / Le Page flintlock



USA 634-005

Revolver avanzatica
Muzzleloading revolver

USA 634-072

Acciarino / Flint lock



USA 634-108

Germano / Big wild duck



USA 634-109

Beccaccia / Woodcock



USA 634-120

Cinghiale / Wild-Boar



USA 634-121

Cane in Corsa / Dog



USA 634-123

Cacciatore
Hunter with dog

USA 634-130

Camoscio / Chamois



USA 634-132

Starna / Partridge



USA 634-133

Beccaccino / Snipe



USA 634-134

Capriolo / Roe-Buck



USA 634-135

Fagiano / Pheasant



USA 634-138

Beccaccia Piccola
Small woodcock

USA 634-140

Trofeo cinghiale
Wild-boar head

USA 634-144

Trota / Trout



USA 634-146

Carabina / Carbine



USA 634-148

Cedrone / Capercaillie



USA 634-149

Pesce Spada / Sword fish



USA 634-151

Salmon / Salmon



USA 634-152

Testa Fagiano
Pheasant head

USA 634-153

Tonno / Tunny



USA 634-155

Lepre / Hare



USA 634-157

Pescatore / Fisherman



USA 634-158

Germano Piccolo
Wild-duck

USA 634-162

Testa Setter / Setter head



USA 634-163

Testa Pointer
Pointer head

USA 634-175

Revolver colt S.A.
Colt S.A. revolver

USA 634-167

Fucile Winchester / Winchester rifle



USA 634-342

Testa Cavallo / Horse head



USA 634-343

Bufalo / Buffalo



USA 634-344

Orso / Bear



USA 634-345

Trofeo Bisonte
Bison head

USA 634-346

Setter



USA 634-347

Cervo / Deer

MUZZLE LOADING WORLD CHAMPION MEDALS

1983 VERSAILLES:

1 Gold - 1 Silver - 3 Bronze

1985 MADRID:

1 Gold - 1 Bronze

1987 TORONTO:

1 Gold - 2 Silver - 2 Bronze

1989 PFORZHEIM:

5 Gold (2 W.R.) - 1 Silver - 2 Bronze

1990 LEUSDEN:

5 Gold - 2 Silver - 3 Bronze

1992 CAMP PERRY:

5 Gold - 2 Silver - 3 Bronze

1994 CHUR:

5 Gold (1 W.R.) - 4 Silver - 3 Bronze

1996 WARWICK:

8 Gold (1 W.R.) - 7 Silver - 6 Bronze

1998 WARWICK:

6 Gold - 6 Silver - 8 Bronze

2000 ADELAIDE:

5 Gold - 7 Silver - 12 Bronze

2002 LUCCA:

6 Gold - 9 Silver - 8 Bronze

2004 BATESVILLE:

13 Gold - 10 Silver - 8 Bronze

2006 BORDEAUX:

13 Gold (1 W.R.) - 11 Silver - 11 Bronze

Siamo associati / We are member of



As Pedersoli shooters Association

and sponsor of



Si ringrazia / We thanks: Mr. Paul Calle and Mr. Chris Calle

Paul Calle

Le creazioni artistiche di Paul Calle riflettono la sensazionale realtà sia dell'epopea western americana, sia di quella in cui l'artista vive.

Per Paul Calle, le dimensioni dell'arte possono avere la stessa vastità delle selvagge praterie dell'ovest con gli infiniti spazi aperti, ma possono essere anche racchiuse in quelle piccole scene storiche che egli cattura e riversa sui francobolli delle poste statunitensi.

Paul Calle è un maestro tanto nella pittura a olio quanto nel disegno. Le sue opere, spesso di grandi dimensioni, evidenziano un attento controllo dei particolari e una incredibile sensibilità.

Oltre che nelle collezioni private e corporative, le opere di Paul Calle sono presenti in quelle permanenti di numerose e prestigiose istituzioni, tra le quali la National Portrait Gallery, l'U.S. Department of the Interior e il Gilcrease Museum. L'artista è stato inoltre insignito del premio Nona Jean Hulsey Buyer's Choice al Prix de West Invitational, presentato dal National Cowboy Hall of Fame and Western Heritage Center.

Paul Calle is an artist whose work reflects the dramatic era of America's Western heritage as well as the one in which he lives. For Paul Calle, the dimensions of art can be as vast as the wild, wind-swept plains of the West, as infinite as outer space and as small as the historic scenes he captures on postage stamps for the United States Postal Service.

Paul Calle is a master of both the oil painting and the pencil drawing. His drawings often very large show incredible control and sensitivity; they have the quality of fine etchings.

In addition to major corporate and private collections, Calle's artwork is in the permanent collections of numerous prestigious institutions including The National Portrait Gallery, the U.S. Department of the Interior and the Gilcrease Museum.

Paul Calle received the distinguished Nona Jean Hulsey Buyer's Choice Award at the Prix de West Invitational, presented by the National Cowboy Hall of Fame and Western Heritage Center.



Chris Calle

Chris, figlio dell'artista Paul Calle, è cresciuto nel mondo dell'arte western, accompagnando fin da piccolo il padre nei suoi viaggi di "ricerca" nell'ovest americano. Queste esperienze in giovane età hanno formato le basi del suo profondo interesse nella storia del West e del suo desiderio di documentarlo con il disegno e con la pittura.

I toccanti ritratti di Chris Calle, raffiguranti i rudi cacciatori delle montagne e i fieri rappresentanti delle popolazioni native, raccontano la storia di coloro che sono stati i veri protagonisti del leggendario West americano.

The son of Western Artist Paul Calle, Chris grew up around the world of Western Art, often traveling with his father on research trips throughout the American West. From a young age these experiences formed the basis of his deep interest in the history of the American West and his desire to one day document them in pencil and paint.

Chris Calle's engaging portraits of the rugged men of the mountains and the proud Indian tell the story of their lives, the story of the American West.

In copertina / On the cover : When trail cross, Paul Calle

In 3° di copertina / On 3rd cover: They call him Caleb, Chris Calle